

Axial piston variable displacement pump type V60N, Serie 03

mainly for mobile applications, commercial trucks etc.
Open circuit

In/line

Nominal pressure = 350 bar (5075 psi)
Maximum pressure p_{\max} = 400 bar (5800 psi)
Geometric displacement V_{\max} = 60, 90 or 110 cm³/rev (3.7, 5.5 or 6.7 cu in)

1.2

Symbol

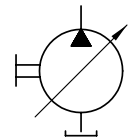
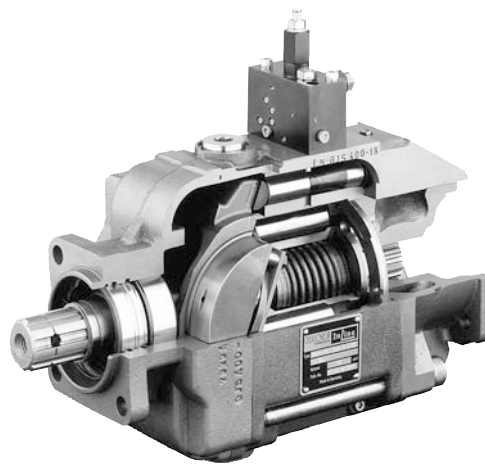

1. General information

This variable displacement pump with its rugged construction is designed for direct mounting at the auxiliary drive (P.T.O.) of commercial vehicles and for standard mounting via a SAE-flange.

With a max. displacement of 110 cm³/rev and a peak pressure of 400 bar it is suited for many applications. This is complemented by the high self priming rate and the low noise level.

Long service life is ensured due to the pressurized lubrication of the swash plate bearing shell.

These features can be best employed when the variable displacement pump is combined with the directional spool valves type PSV according to D 7700 ++ and the corresponding over-center valves type LHT and LHDV according to D 7918 and D 7770.

Reversing the rotation direction is very simple and can be done in the field, which helps to adapt the pump to existing applications.

2. Available versions, main data

2.1 Basic pump

Order example: **V60N - 090 R DUN - 1 - 0 - 03/LSN - 2 - 350 - A00/76**

Basic type

Table 1: Nominal size

Coding	060	090	110
Geometric displacement V_g (cm ³ /rev)	60	90	110
Nom. pressure p_{nom} (bar)	350	350	350
Pressure p_{max} (bar)	400	400	400

Direction of rotation:

L = Counter clock wise

R = Clock wise

always facing the drive shaft (note for changing the rotation direction see position 3)

Shaft and flange design:

DU = Spline shaft (DIN ISO 14) with mounting flange ISO 7653-1985, flange-suction port

SU = Spline shaft and mounting flange SAE-C, flange-suction port

Suction connections, see table 3, pos. 4.3

no coding = Ports conforming DIN ISO 228/1 (BSPP)

UNF = Ports conforming SAE J 514

Pressure specification (bar)

no coding = Without stroke limitation (standard)

2 = With stroke limitation (not available for versions with thru-shaft)

2 ... = Pre-set stroke limitation incl. flow specification

Pump controllers, see table 2

Production standard

Additional functions: **0** = Without

Drive shaft version: **1** = Standard

2 = Thru-shaft (only available for type V60N-060 and -110)

Seals:

N = NBR (Nitril) - Standard

V = FKM

Table 2: Pump controllers

Coding	Description
LSN	Load-Sensing controller with integrated pressure limitation
N	Pressure controller, adjustable directly at the pump. The Pressure controller automatically maintains a constant system pressure independant of the required flow. Therefore it is suited for constant pressure systems, where differing flow is required or as efficient pressure limitation of the hydraulic system.
LLSN	Power controller (torque limitation) in combination with LSN Product "Pressure x Displacement" = constant Adjustment range: 25...100% of max. drive torque
LN	Power controller (torque limitation) in combination with pressure controller N Adjustment range: 25...100% of max. drive torque

2.2 Controller

Symbols

Coding **LSN**

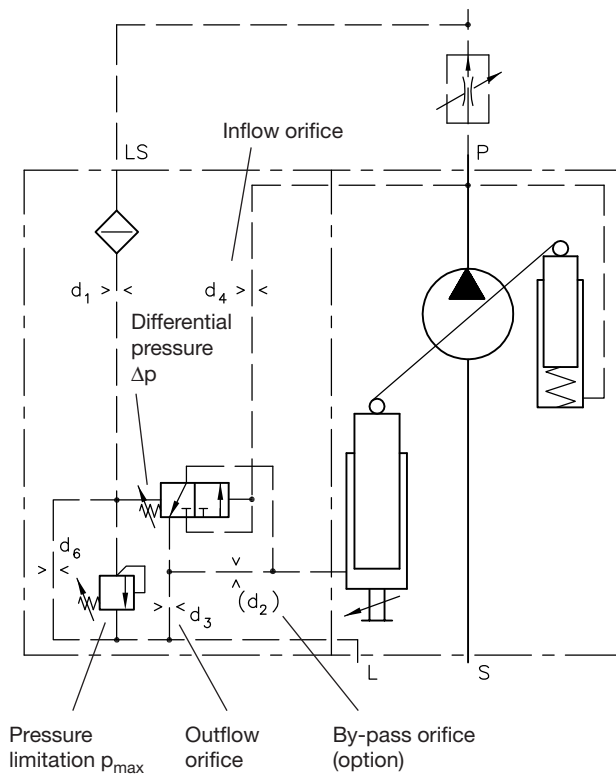

Coding **LLSN**

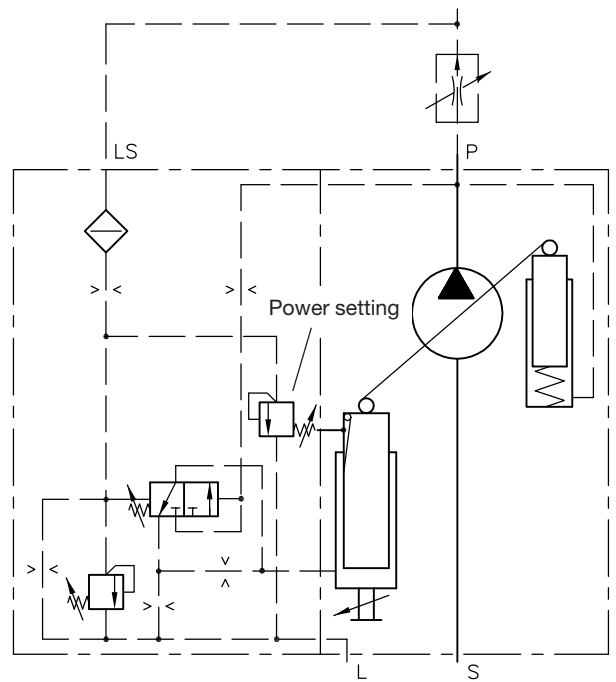

Coding **N**

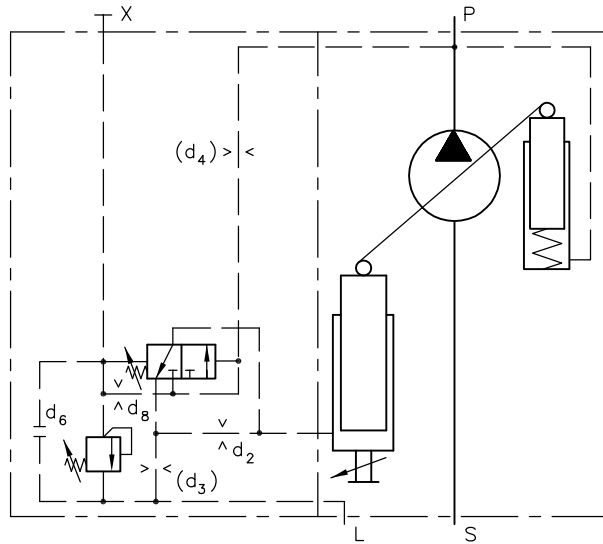

Coding **LN**

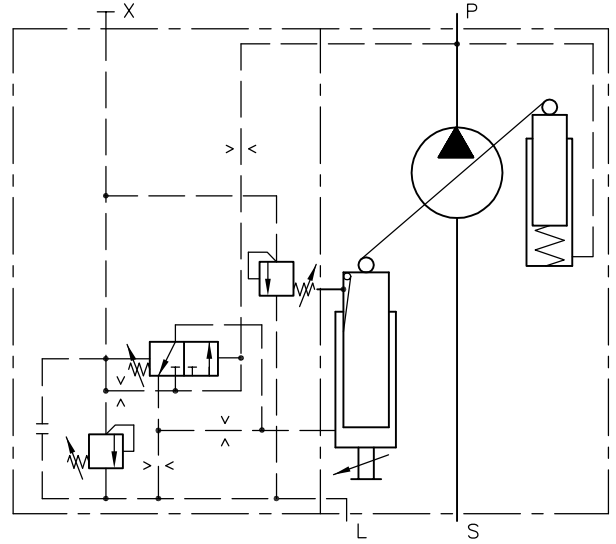

Fitted orifices (standard)

Controller	$\varnothing d_1$	$\varnothing d_2$	$\varnothing d_3$	$\varnothing d_4$	$\varnothing d_6$	$\varnothing d_8$
LSN	0.9	-	0.7	1.2	2x0.4	-
LLSN	0.9	-	0.7	1.2	2x0.4	-
N	-	0.7	-	-	-	0.7
LN	-	0.7	-	-	-	0.7

3. Additional parameter

3.1 General

Calculation
of the nom. sizes:

Flow rate
$Q = \frac{V_g \cdot n \cdot \eta_v}{1000} \text{ (l/min)}$

Torque
$M = \frac{1,59 \cdot V_g \cdot \Delta p}{100 \cdot \eta_{mh}} \text{ (Nm)}$

Power
$P = \frac{2\pi \cdot M \cdot n}{60000} = \frac{M \cdot n}{9549} = \frac{Q \cdot \Delta p}{600 \cdot \eta_t} \text{ (kW)}$

V_g = Displacement (cm³/rev)

η_v = Volumetric efficiency

Δp = Differential pressure (bar)

η_{mh} = Mechanical-hydraulic efficiency

n = Speed (rpm)

η_t = Total efficiency ($\eta_t = \eta_v \times \eta_{mh}$)

Nomenclature

Axial piston pump according to the swash plate principle

Mounting

At the auxiliary drive of commercial vehicles (flange ISO 7653-1985 for trucks) or flange assembly (flange SAE-C)

Surface

nitro-carb hardened

Direction of rotation

Clock wise or counter clock wise

Changing the rotation direction

Turn the end plate (see dimensions, pos. 4) and change the port plate, see also B 7960 N

		V60N-060	V60N-090	V60N-110
Order No.:	Port plate			
	clock wise	79-40846.00	79-40518.00	79-29763.00
	counter clock wise	79-40847.00	79-40519.00	79-29765.00

Installed position

Any (observe the installation notes!)

Hydraulic fluid

Hydraulic oil acc. to DIN 51524 table 2 and 3; ISO VG 10 to 68 acc. to DIN 51519
Viscosity range: min. approx. 10; max. approx. 1000 mm²/sec
Optimal operation range: approx. 10...35 mm²/sec
Also suitable are biologically degradable pressure fluids type HEES (synth. Ester) at operation temperatures up to approx. +70°C.

Temperature

Ambient: approx. -40...+60°C
Fluid: -25...+80°C, pay attention to the viscosity range!
Start temperature down to -40°C is allowable (Pay attention to the viscosity range during start!), as long as the operation temperature during subsequent running is at least 20K (Kelvin) higher.

Filtration

Recommended contamination level \leq 18/13 conforming DIN ISO 4406

Initial operation

All pipes should be flushed with the same fluid intended for the later service prior to initial operation. The housing of the pump should be primed via the upper case drain port. The case drain line must be routed in such a way that running empty is prevented.
The pressure limiting valve should be set to 50 bar or lower for initial operation and the first few minutes of regular service.

Max. perm. housing pressure

1 bar

Approved by

DaimlerChrysler AG, auxiliary drive NA 121-2c (only V60N-090)

	V60N-060	V60N-090	V60N-110
Angle of the swash plate	21.5°	21.5°	21.5°
Required inlet pressure (absolute) for open circuit	0.85 bar	0.85 bar	0.85 bar
Max. permissible drive torque	430 Nm	530 Nm	600 Nm
Max. permissible torque for the tru-shaft, dep. on flange	100 Nm	---	600 Nm
Max. rev. rating when self priming and max. angle of the swash plate at 1 bar absolute inlet pressure	2500 rpm	2300 rpm	2200 rpm
Min. rev. rating for permanent running	500 rpm	500 rpm	500 rpm
Required torque at 100 bar	100 Nm	151 Nm	184 Nm
Drive power for 250 bar and 2000 rpm	53 kW	79.5 kW	97.2 kW
Mass (weight) complete with controller	22 kg	25.8 kg	28 kg
Weight torque	30 Nm	35.3 Nm	40 Nm
Inertia moment	0.005 kg m ²	0.008 kg m ²	0.01 kg m ²
Sound level at 250 bar, 1500 rpm and max. swash plate angle (Measured in a sound measuring room DIN ISO 4412, distance 1m)	75 dB(A)	75 dB(A)	75 dB(A)

3.2 Curves

Delivery flow and performance

The curves illustrate delivery flow/pressure (without controller). Drive power at max. swash plate angle and drive power at zero stroke at 1500 rpm.

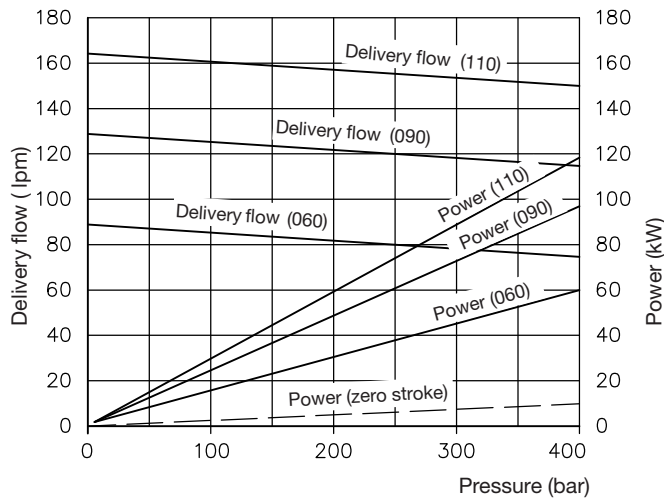

Inlet pressure

The curve was taken at viscosity 75 mm²/sec and max. swash plate angle

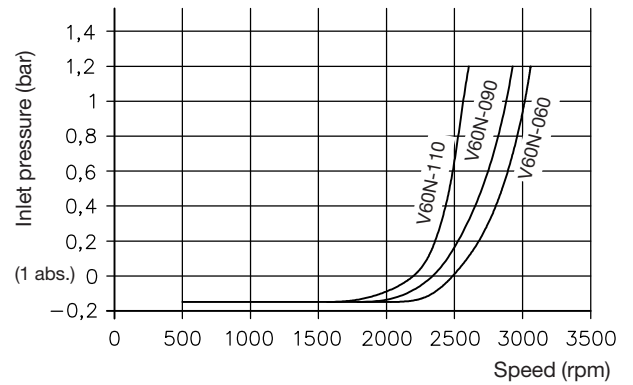

Controller curve

Coding L

Pressure / Delivery flow

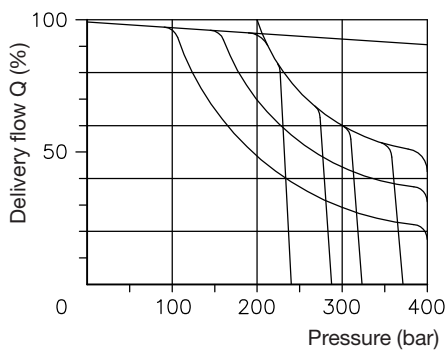

Response time T1 (LSN-controller)

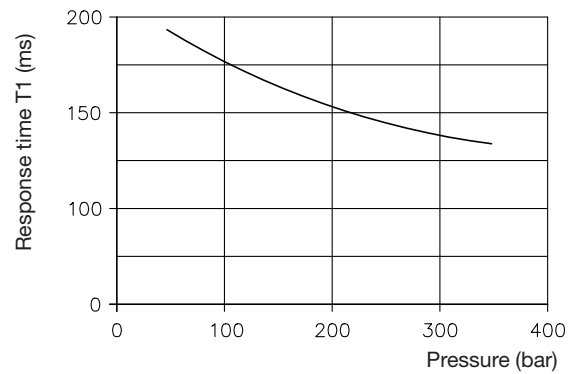

Coding LSN

approx. 4 bar

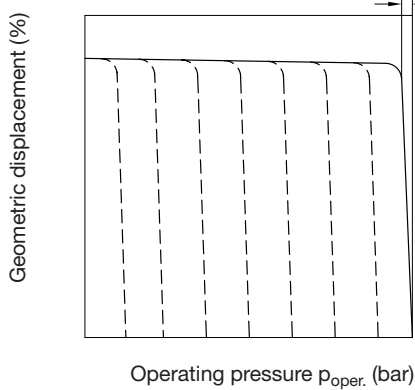

Response time T2 (LSN-controller)

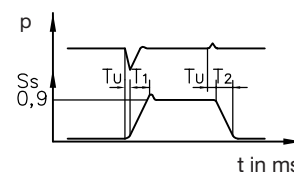
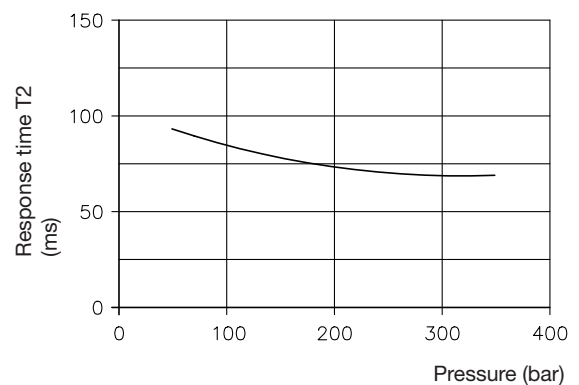

S_s = Displacement

T_u = Delay < 3 ms

T_1 = Response time min to max

T_2 = Response time max to min

p = Pressure

LS-line min. length 1.5 m, min. internal diameter 12 mm

4. Unit dimensions

All dimensions in mm, subject to change without notice!

4.1 Basic pumps

Type **V60N-060**

Here coding **SU**
Spline shaft SAE-C
14T-12/24 DP

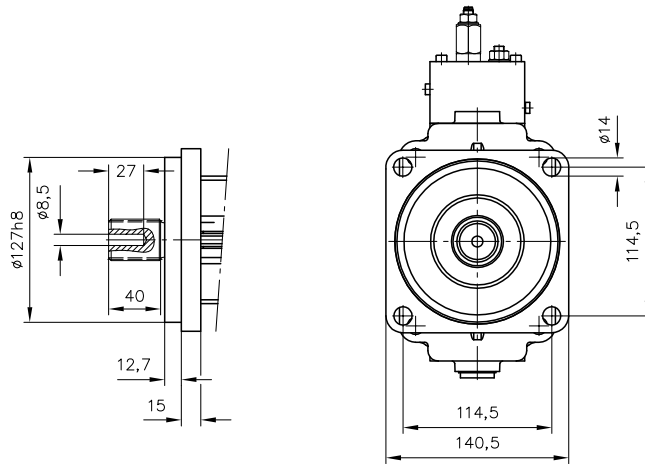
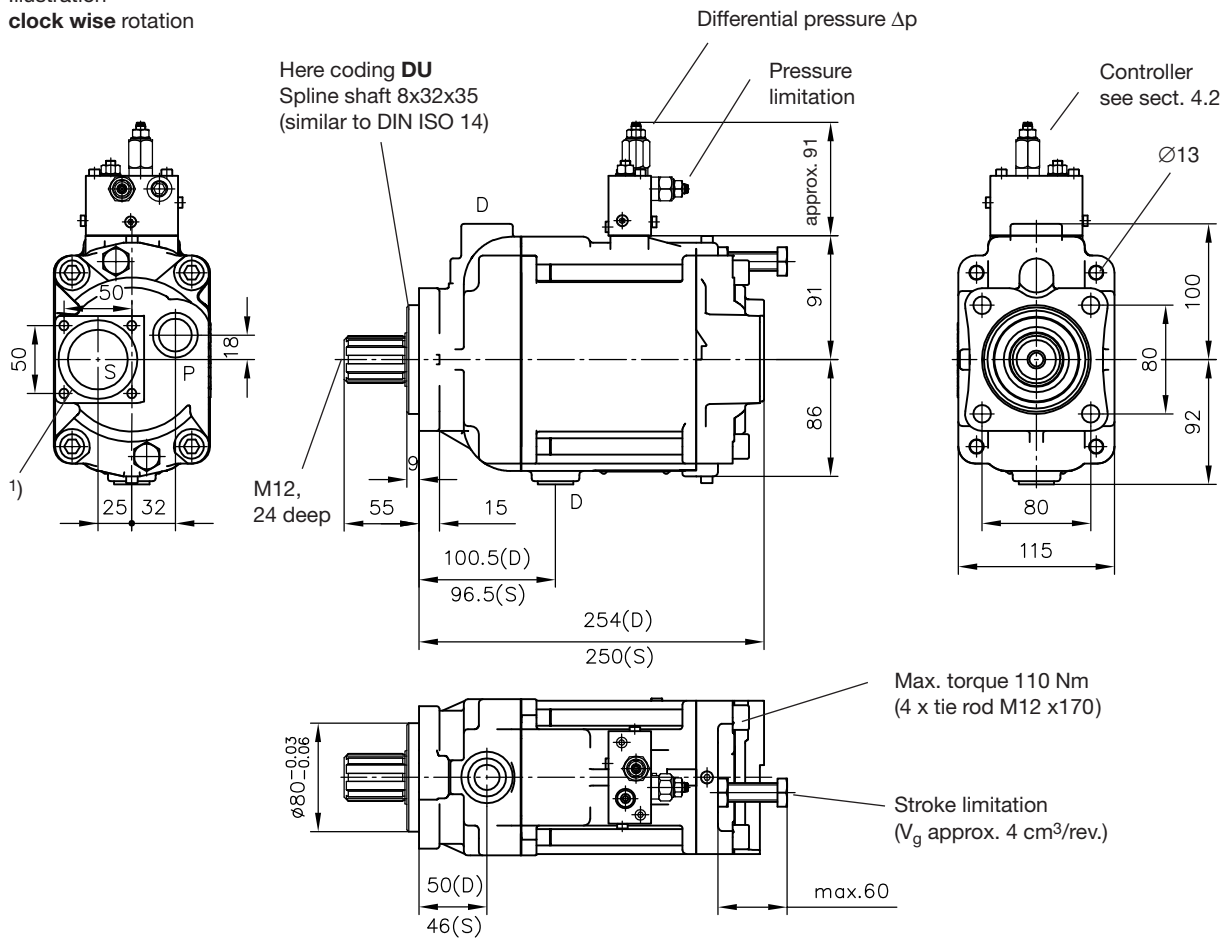

Illustration
clock wise rotation



- 1) Mounting kit is scope of delivery with the intake acc. to sect. 4.3 (part No. 7993355). It consists of:
- 4x skt.-head screw M8x16-8.8
 - O-ring 44.2x3 NBR 70 Sh
 - 2 brackets

Ports (DIN ISO 228/1 (BSPP):

- P = Pressure outlet G 3/4
- S = Flange-suction port
- D = Case drain G 3/4

Coding **UNF** ports conforming SAE J 514:

- P = 1 5/16-12 UN-2B
- S = 1 7/8-12 UN-2B
- D = 1 5/16-12 UN-2B
- LS = G 1/4 (DIN ISO 228/1 (BSPP))
with adaptor for 7/16-20 (SAE-4)

Type V60N-090

Coding "DU" and "SU"

counter clock wise rotation direction
(facing the shaft end)

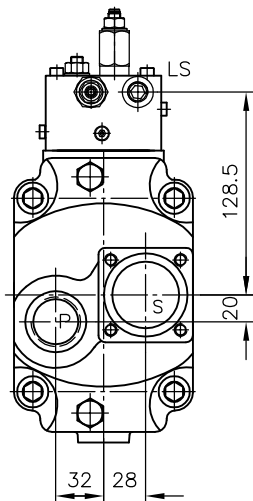

Coding **SU**
Spline shaft SAE-C
14T-12/24 DP

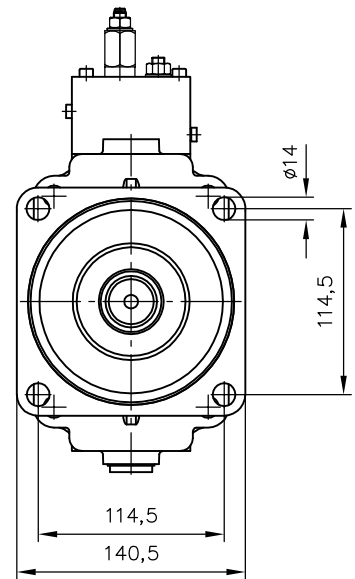
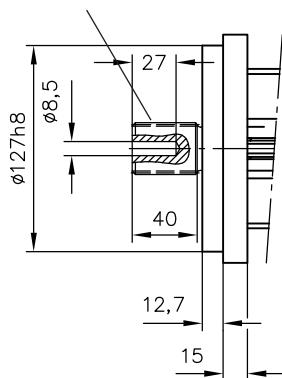

Coding "DU" and "SU"

clock wise rotation direction
(facing the shaft end)

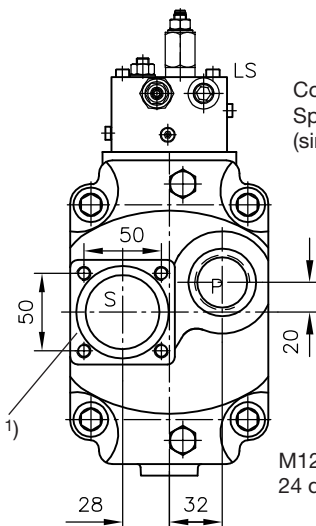

Coding **DU**
Spline shaft 8x32x35
(similar to DIN ISO 14)

M12,
24 deep

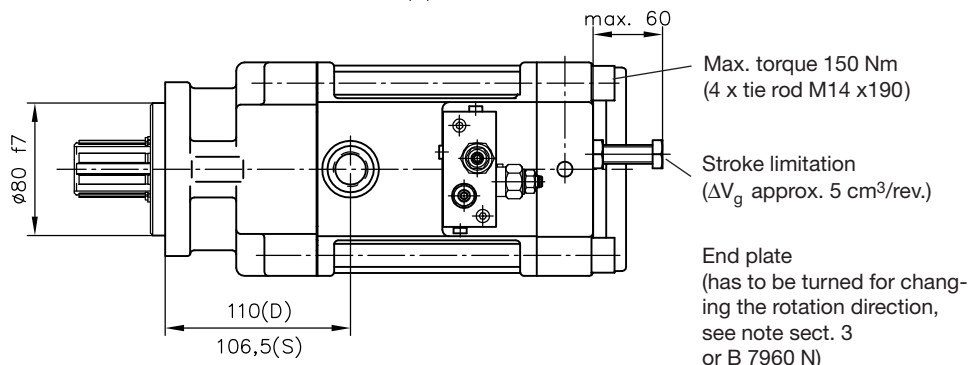
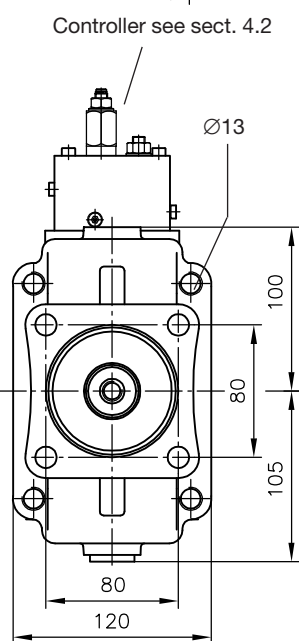
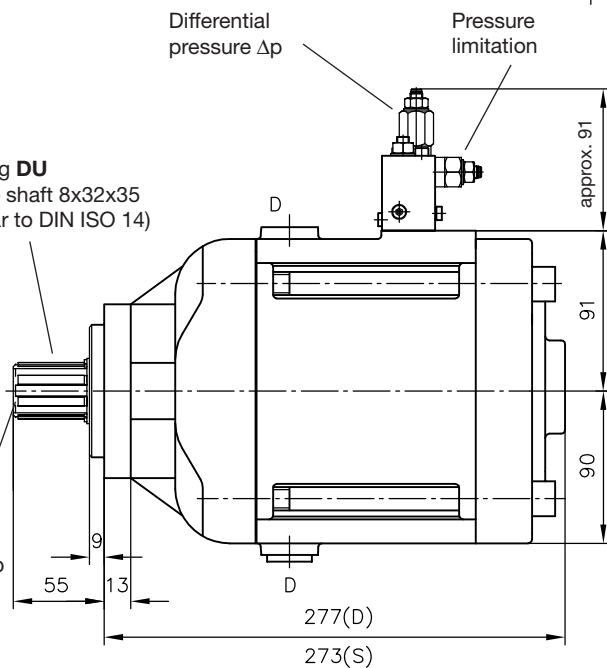

- 1) Mounting kit is scope of delivery with the intake acc.to sect. 4.3 (part No. 7993355). It consists of:
- 4x skt.-head screw M8x16-8.8
 - O-ring 44.2x3 NBR 70 Sh
 - 2 brackets

Ports DIN ISO 228/1 (BSPP):

- P = Pressure outlet G 1
- S = flange-suction port
- D = Case drain G 3/4

Coding **UNF**

ports conforming SAE J 514:

- P = 1 5/16-12 UN-2B
- S = 1 7/8-12 UN-2B
- D = 1 5/16-12 UN-2B
- LS = G 1/4 (DIN ISO 228/1(BSPP)) with adaptor for 7/16-20 (SAE-4)

Type V60N-110

Coding **SU**

Spline shaft SAE-C14T-12/24 DP

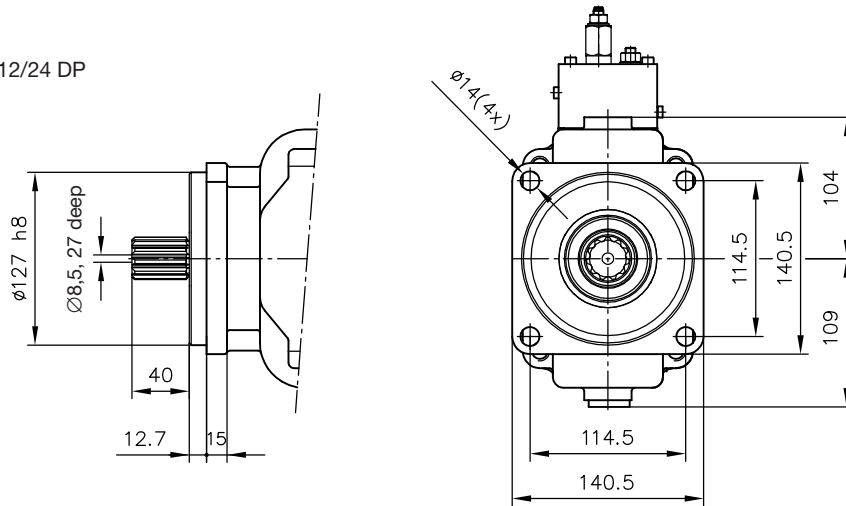
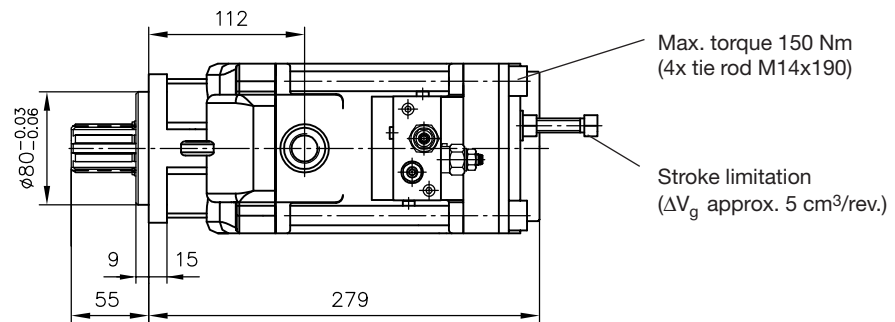
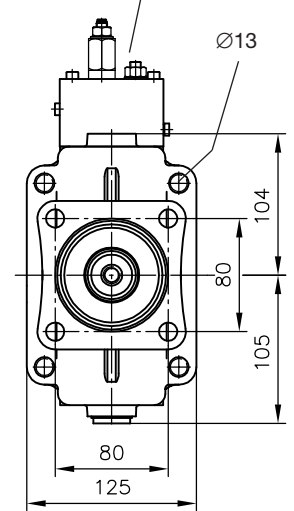
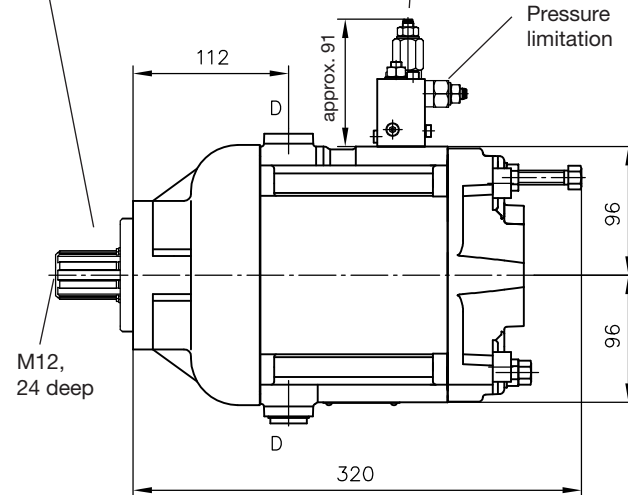
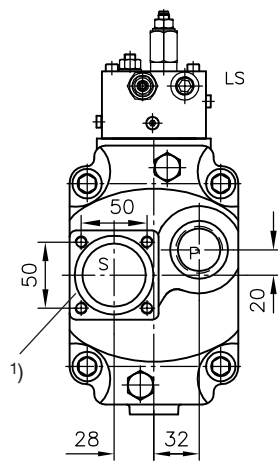

Illustration
clock wise rotation
direction
(facing the shaft end)

Coding **DU**
Spline shaft 8x32x35
(similar to DIN ISO 14)

Differential pressure Δp

Controller see sect. 4.2



- 1) Mounting kit is scope of delivery with the intake acc.to sect. 4.3 (part No. 7993355). It consists of:
- 4x skt.-head screw M8x16-8.8
 - O-ring 44.2x3 NBR 70 Sh
 - 2 brackets

Ports DIN ISO 228/1 (BSPP):

- P = Pressure outlet G 1
- S = flange-suction port
- D = Case drain G 3/4

Version with thru-shaft

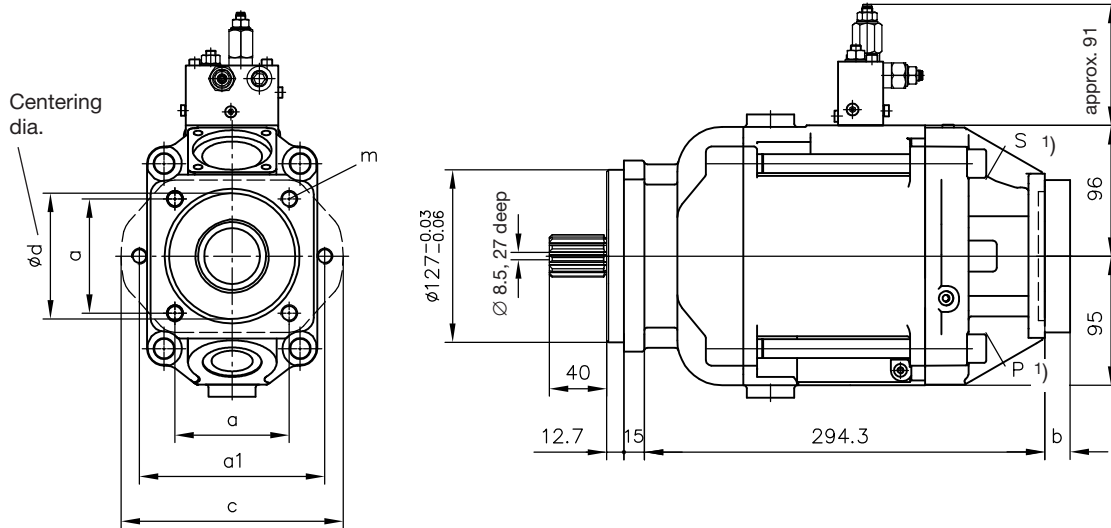

Order example: V60N-110 RSUN-2-0-01/LLSN-350- **SAE-B/4** -A00/76

Available flange design incl. coupling

Coding	Description	Suited for spline shaft	a	a1	b	c	Ød	m
- SAE-A	Flange SAE-A	9T-16/32 DP	84	146.4	25	150	82.55	4xM10, 15 deep
- SAE-B/2	Flange SAE-B-2-hole	13T-16/32 DP	-	146	20	165	101.6	2xM12
- SAE-B/4	Flange SAE-B-4-hole	13T-16/32 DP	89.8	-	-	-	101.6	4xM12, 15 deep
- SAE-C/4	Flange SAE-C-4-hole	14T-12/24 DP	114.5	-	32	213	127	4xM12, 15 deep
- SAE-C/2	Flange SAE-C-2-hole	14T-12/24 DP	-	181	32	213	127	2xM16

Note: All additional support has to be provided for pump combinations

1) With clock wise rotation

4.2 Controller

Type LSN, LN, N and LLSN

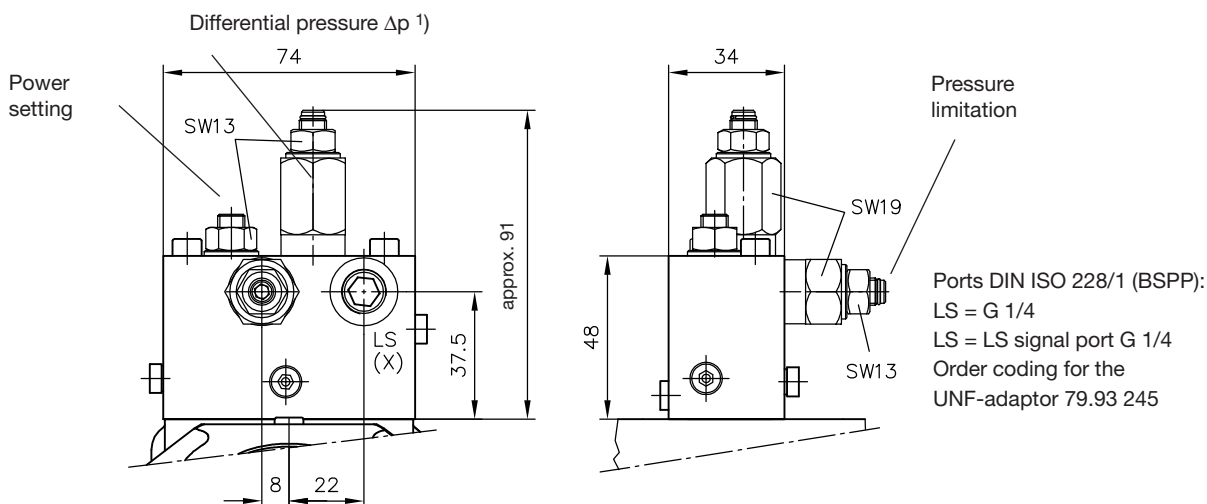

Pressure adjustment

	Pressure range (bar)	Δp (bar) /rev.
Pressure limitation	50 ... 400	100
Differential pressure Δp 1)	18 ... 45	10

SW = a/f

1) Applies only to controlles type LSN and LLSN; pre-set at HAWE at 28 bar

4.3 Suction intakes

Order example: V60N - 090 R DU N - 1 - 0 - 01/LSN - 350 - **A00/76**

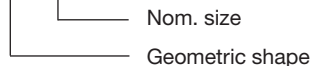

Table 3: Suction intakes

Nom. size (N)	Q_{max} (l/min)	Straight		45°		90°		Thread
		A00/..	A45/..	A45/..	A90/..	A90/..	A.	
		h	h	k	h	k	h	
38 (1 1/2") 2)	75	65	-	-	-	-	-	
42	90	-	85	40	-	-	-	
50 (2")	125	65	96	40	53	84	-	
64 (2 1/2")	190	90	96	40	109	129	-	
76 (3")	250	106	106	40	-	-	-	
6 (G 1 1/4)	125	-	-	-	-	-	21	
7 (G 1 1/2)	200	-	-	-	-	-	28.5	

2) **Attention:**
Should be used for reduced flow only!

Mounting kit is scope of delivery with the intake acc.to sect. 4.3 (part No. 7993355). It consists of:
- 4x skt.-head screw M8x16-8.8
- O-ring 44.2x3 NBR 70 Sh
- 2 brackets

G = BSPP

A00/...

A45/..

A90/...

A6
A7

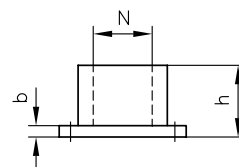
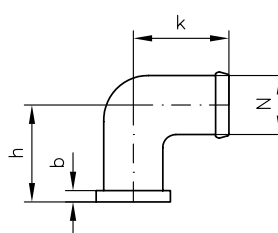
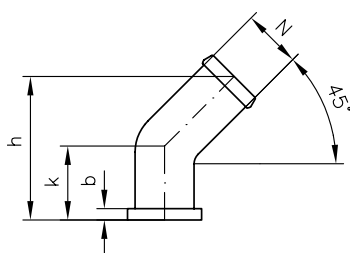
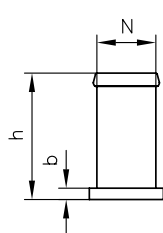

Dimension b: 6.2 mm