



aerospace
climate control
electromechanical
filtration
fluid & gas handling
hydraulics
pneumatics
process control
sealing & shielding



icount Particle Monitoring
ACM20, ACM20 Z2, IPD and IBS
Aviation fuel + hazardous zones monitoring



ENGINEERING YOUR SUCCESS.

Parker Hannifin Corporation

ENGINEERING YOUR SUCCESS.



The Parker Brand Promise

Parker is the global leader in motion and control technologies, partnering with its customers to increase their productivity and profitability.

A global Fortune 300 company with customers in 48 countries, Parker Hannifin is the world's leading supplier of hydraulic, pneumatic, and electro-mechanical systems and components. Customers rely on Parker for engineering excellence, world-class manufacturing and outstanding customer service to provide comprehensive application solutions that are second to none.

- More than USD 12.1 billion in sales
- 298 plants worldwide
- 12,000 distributors
- 449,000 customers
- Serving 1,200 distinct markets
- Listed as PH on the New York Stock Exchange

aerospace
climate control
electromechanical
filtration
fluid & gas handling
hydraulics
pneumatics
process control
sealing & shielding

Let Parker become part of your design team. Whether you need to develop new products, redesign existing applications, or design completely new systems, Parker offers unparalleled engineering expertise.



Fluid contamination monitoring

Parker Filtration continues, through technical expertise and proven products, to retain a world class position as an innovator in designing and manufacturing fluid contamination monitoring and analysis equipment ensuring our customers can maintain the cleanliness of their hydraulic systems.

More recently Parker Filtration's CMC development engineers have been working successfully on designing and manufacturing a 'family' of icount contamination analyzers, particle detectors and bottle samplers intended to provide accurate and repeatable monitoring of contamination in AvTur and other hydrocarbon fuels in accordance with the Energy Institute (EI) Method IP564.

icountACM20 Lab Unit

Aviation Fuel Contamination Monitoring

Note: For information on icountPD for aviation fuels see page 369



A unique product with pedigree

DEFSTAN 91-91 Issue 6 Jet A-1 Fuel Specification, adopts particle counting.

Development work carried out by the CMC engineers, in conjunction with Exxon Mobil Aviation, highlighted the need for an alternative test method to determine the levels of dispersed contamination in Jet fuel. 5 years of field testing and development of the already established and successful icountLCM20 Hydraulic Laser Particle Counter saw the introduction of the Parker icountACM20 with enhanced software providing the user with a better understanding of the contamination present in a sample.

As the benchmark particle counter for use in measuring the levels of contamination in fuels, the icountACM20, as per the UK's Energy Institute Test Method IP564, has now been included in the DEFSTAN 91-91 Issue 6 Jet Fuel Specification as a report only test alongside the current Gravimetric test method (IP423 or ASTM D5452) and Clear & Bright Visual test method (IP216 or ASTM D2276)



Contact Information: Product Features:

Parker Hannifin
Hydraulic Filter Division Europe

European Product Information Centre
Freephone: 00800 27 27 5374
(from AT, BE, CH, CZ, DE, EE, ES, FI, FR, IE, IT, PT, SE, SK, UK)
filtrationinfo@parker.com

www.parkerhfde.com

- icountACM20 monitors aviation fuel contamination to DEFSTAN 91-91 Issue 6 Jet A-1 fuel specification.
- Energy Institute Test Method IP 564.
- 2-minute test procedure.
- Fully manufactured by Parker with 20 years experience in the Particle Counter Measuring market.
- Laser optical scanning analysis.
- Multi-standard ISO cleanliness reporting.
- On-board, rear-mounted pump enables monitoring possibilities. For example: Fuel storage/ vehicle tanks and fuel storage drums.
- Latest averaging software as standard.
- Downloader software.

icountACM20 Lab Unit

Aviation Fuel Contamination Monitoring



Features & Benefits

Test Time:

2 minutes

Repeat Test Time:

Every 2 minutes (Manual testing), every 6 minutes (automatic)

Principle of Operation:

Optical scanning analysis and measurement of actual particles and inference to water presence

Primary Output:

$\geq 4\mu(c)$, $\geq 6\mu(c)$, $\geq 14\mu(c)$, $\geq 21\mu(c)$, $\geq 25\mu(c)$, $\geq 30\mu(c)$ counts per ml

Secondary Diagnostic Output:

% Volume Distribution, via graphical display on handset and printout

International codes:

ISO 7-22 in accordance with ISO 4406-1999

Data entry:

32 character two line dot matrix LCD. Full alpha numeric entry facility on keypad

Data retrieval:

Memory access gives test search facility for up to 300 saved tests

Calibration:

In accordance with Parker Calibration Procedure CM20-N, which complies to ISO11171:1999, Clause 6 (Omitting Annex F)

Re-calibration:

Every 12 months by a dedicated Parker Service Centre (Consult Parker) as required under strict EI methods

Max. working pressure:

420 bar

Operating Temperature:

+5°C to +80°C

Memory store:

300 test capacity

Computer compatibility:

Interface via RS 232 connection @ 9600 baud rate (USB serial cable to RS232 option available)

Laboratory sampling:

Utilizes on-board rear mounted pump

Portability:

Only 8 kg. icount ACM20 has its own battery pack and carry case with wheels 13kg total weight

Power requirement:

12vDC input, 6 x 'D' Cell batteries or rechargeable battery pack

Printer facility:

Integral 16 column printer for hard copy data

Certification:

Complies with all relevant EC declarations of conformity

icount ACM20 Case Mounted Pump

- Integrated Pump assembly incorporated onto the ACM20 unit.
- Powered directly from ACM20 unit, LED power indication with no additional power supplies required.
- Direct sampling from fuel sample bottles or tank via 3 metre inlet suction tube.
- Incorporated double speed flush and test sequence.
- Managed flow rate/correct volume sample as per IP 564 test method.

FACT: icountACM20 is fully compliant with the EI (Energy Institute) test method

Applications

The Parker icountACM20 Portable Particle Counter has been developed from existing technology for monitoring contamination in AvTur and other hydrocarbon fuels, in accordance with the Energy Institute (EI) Method IP 564.

In addition, the ACM can also be used to monitor various fuels from existing sampling points in locations from refineries, pipelines, distribution terminals, airport fuel supply systems all the way through to the point of uplift into aircraft*.

* Hot works permit required for online sampling (ATEX Zone 2 unit available). Page 14.

- **Fuel Testing Laboratories – DEFSTAN 91-91 Issue 6**

In order to better understand dispersed contamination in jet fuel, particle counting is now included alongside existing laboratory techniques

- **Bottle Sampling - Energy Institute (EI) - IP 564**

Laboratory determination of the level of dispersed contamination in aviation kerosine using an Automatic Particle Counter (APC)

- **Replace Clear & Bright and Gravimetric**

With the introduction of the icount ACM20, all subjectivity surrounding Clear & Bright and Gravimetric methods can be removed

- **Also for use on petroleum based hydraulic applications (Skydrol compatible available)**

Suitable for use with mineral oil and petroleum based fluid as per standard hydraulic particle counter, reporting fluid cleanliness to ISO 4406:1999



Specification

Construction:

ABS structural foam and injection moulded case
Hand-held display - ABS
Keypad fluoro silicone rubber

Mechanical Components:

Brass, plated steel, stainless steel and aluminium

Seals:

Fluorocarbon

Hoses:

Nylon (Kevlar braided microbore). St. steel armoured ends

Flow Rate:

25 - 28ml/min (dictated by CMP) 100ml/min with additional flush button

Fluid Compatibility:

Hydrocarbon Fuel, Mineral Oil. For other fluids consult Parker

Fuse:

1.25 amp fast blow fuse included for overload protection (spare supplied)

icountACM20 Technology:

Patented flow cell, light obscuration

Repeatability/Accuracy:

As per or better than ISO 11171

Coincidence:

40,000 particles per ml

Viscosity Range:

1 -100 centistokes

icountACM20 Weight:

8 kg

Monitor Carrying Case:

Astra Board case

Carrying Case Weight:

5 kg

icountACM20 - rear view

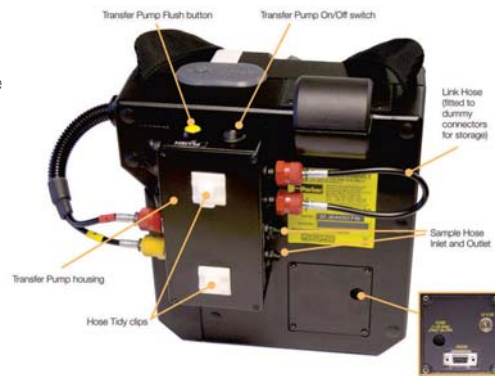

Input Power Socket (note that you will have to remove the plastic dust cap to access the 12Vdc power socket).

A fast blow 1.25A fuse and the RS232 connection are located behind the removable cover plate. The RS232 interface is provided to download all test data stored in the instrument. See the **ParSmart Downloader** software for more information.

Ordering Information

Standard products table - icount ACM20

Product number	Supersedes	Description
ACM202022UK	N/A	icountACM20 (UK)
ACM202022US	N/A	icountACM20 (US)
ACM202022EUR	N/A	icountACM20 (EURO)
ACM202024UK	N/A	icountACM20 with lab kit - UK (DEFSTAN 9191)
ACM202024US	N/A	icountACM20 with lab kit - US (DEFSTAN 9191)
ACM202024EUR	N/A	icountACM20 with lab kit - EURO (DEFSTAN 9191)
ACC6ND000	B84794	1 meter process cable
ACC6NE006	B84816	ParSMART downloader software
ACC6NE019	P843855	icountACM20 transit Case
ACC6NW003	B84746	Vapour/waste bottle assembly
ACC6NE029	B84745	Throttle kit
ACC6NE001	B84645	Millipore adaptor kit
ACC6NE013	B84609	Re-chargeable battery pack
ACC6NE008	B84817	UK power supply
ACC6NE010	B84830	US power supply
ACC6NE009	B84831	Euro power supply
ACC6NE020		UK Offline kit
ACC6NE021	B84832	Euro Offline kit
ACC6NE022		US Offline kit
SERMISC067	N/A	500ml verification fluid
ACC6NE015	B84702	Printer reel (x5)
ACC6NE014	P843702	Printer ribbon (x1)



Field Monitoring - icountACM202022

For use in non-hazardous areas, the icountACM202022 is designed for online sampling of hydrocarbon fuels and hydraulic systems, utilising existing "quick connect" sampling points such as the Millipore Adaptor.

Note 1: Part numbers featured with bold highlighted codes will ensure a 'standard' product selection.

Note 2: Alternate displayed part number selection will require you to contact Parker Filtration for availability.

Note 3: Selected spare parts - for a full list contact Parker.

* Hot works permit required for online sampling.

icountACM20 Lab Unit

Aviation Fuel Contamination Monitoring

DEFSTAN 91-91 Issue 6
Defence Standard 91-91 is the specification for aviation turbine fuel, which the United Kingdom Civil Aviation Authority (CAA) has agreed is under the technical authority of the Director of the Defence Fuels Group.

IP 564

Laboratory determination of the level of dispersed contamination in aviation kerosene using an Automatic Particle Counter (APC). This standard describes a method for determining the level of dispersed contamination in aviation kerosene fuels, specifically dirt particles and water droplets in the range from $\geq 4\mu(c)$ to $\geq 30\mu(c)$. This method relates specifically to Aviation fuels but the equipment can be used on all fuels, petroleum and mineral based fluids.

Note:

The mandatory implementation date for IP 564 test method "Determination of the level of cleanliness of aviation turbine fuel - laboratory automatic particle counter" is July 1st 2009. It is the specification authorities intention to replace current test methods with particle counting at the earliest opportunity.

IP 564 Procedure

Step 1

The apparatus shall be set up in accordance with Parker's operating instructions.

Step 2

Test Portion Preparation:

Decant a minimum of 450ml of the field sample into a clean test portion container.

Step 3

Prior to starting a test, tumble the test portion end over end for 60 seconds to ensure any settled particles are redistributed.

Step 4

Turn on the Case Mounted Pump and flush for 60 seconds. Do not press the fast flush button. While flushing, enter the test identifier (see manual).

Step 5

Following the flush, start a test by turning the blue valve in the direction indicated. Perform a further 3 tests. (4 in total).



icountACM20 Z2

ATEX Approved Portable Particle Counter



For use in explosive and hazardous areas

icountACM20 Z2 is designed to be used to monitor various fuels from existing sampling points in hazardous locations such as refineries, pipelines, distribution terminals, airport fuel supply systems all the way through to the point of uplift into aircraft. With Zone 2 classification, the icount ACM20 Z2 is the worlds **only** ATEX approved particle counter.



Contact Information:

Parker Hannifin
Hydraulic Filter Division Europe

European Product Information Centre
Freephone: 00800 27 27 5374
(from AT, BE, CH, CZ, DE, EE, ES, FI, FR, IE, IT, PT, SE, SK, UK)
filtrationinfo@parker.com

www.parkerhfde.com

Product Features:

- Assembled in an approved and certified stainless steel enclosure to comply with ATEX Directive 94/9/EC.
- Can be used in explosive and hazardous areas, including offshore and mining applications.
- ATEX Zone II
- Certified to CE Ex II 3 G Ex nR/nL IIC T6
- "A" Class product defined for the Aviation market.
- ATEX approved Handset and keypad.
- Suitable for use with mineral oil and petroleum based fluid as per ACM20/LCM20 particle counters.

icountACM20 Z2

ATEX Approved Portable Particle Counter

Features & Benefits

Test Time:

2 minutes.

Repeat Test Time:

Every 2 minutes (Manual testing) Every 6 minutes (Automatic).

Principle of Operation:

Optical scanning analysis and measurement of actual particles and inference to water presence.

Primary Output:

$\geq 4\mu(c)$, $\geq 6\mu(c)$, $\geq 14\mu(c)$, $\geq 21\mu(c)$, $\geq 25\mu(c)$, $\geq 30\mu(c)$ counts per ml.

Secondary Diagnostic Output:

% Volume Distribution, via graphical display on handset.

International codes:

ISO 7-22 in accordance with ISO 4406-1999

Data entry:

32 character two line dot matrix LCD. Full alpha numeric entry facility on keypad.

Data retrieval:

Memory access gives test search facility for up to 300 saved tests.

Calibration:

In accordance with Parker Calibration Procedure CM20-N, which complies to ISO11171:1999, Clause 6 (Omitting Annex F).

Re-calibration:

Every 12 months by a dedicated Parker Service Centre (Consult Parker).

Max. working pressure:

420 bar.

Operating Temperature:

+5°C to +80°C

Memory store:

300 test (scrolling memory) capacity.

Computer compatibility:

Interface via RS 232 connection @ 9600 baud rate.

Portability:

15 kg. ACM20 has its own battery pack and carry case with wheels.

Power requirement:

Rechargeable battery powered or via the 12vDC input.

System connection:

Via Millipore adaptor with flow restriction through supplied needle valve.

Certification:

Complies with all relevant EC declarations of conformity.

Printer facility:

No printer. Data download only.

Online Commission Kit

- a – icountACM20 Zone II Particle Counter
- b – Battery Charger
- c – Process Cable
- d – User Manual
- e – Downloader Software
- f – Throttle Kit
- g – Millipore Adaptor Assembly
- h – Aluminium Case
- i – Bottle Assembly

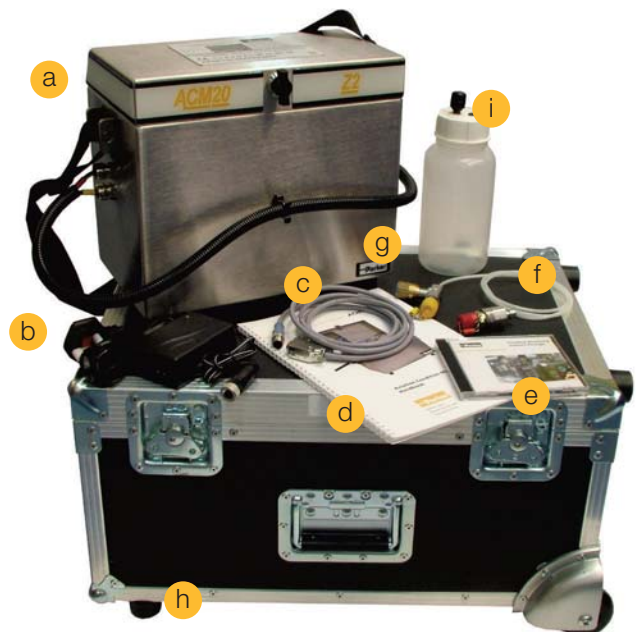

Specification

Construction:

Unit: Stainless Steel

Carrying case: ABS

Hand-held display: ABS

Keypad: polyester membrane

Mechanical components:

Brass, plated steel, stainless steel and aluminium

Seals: Fluorocarbon

Hoses: Nylon (Kevlar braided microbore)

Fluid compatibility:

All fuels. For other fluids consult Parker

Internal rechargeable battery:

Note: ONLY to be charged outside of the hazardous area, with the unit switched off

Fuse:

1.25A fast blow fuse included for overload protection

Return to Parker Hannifin if fuse is blown

icountACM20 2032 technology:

Unique optical scanning system

Using icountACM20 Z2

icountACM20 Z2 is designed to be used to monitor various fuels from existing sampling points in hazardous locations from refineries, pipelines, distribution terminals, airport fuel supply systems all the way through to the point of uplift into aircraft. With Zone II classification, the icountACM20 Z2 is the worlds **only** ATEX approved particle counter.



Applications in Fuels

- **Oil Refinery**
 - To count and verify the levels of dispersed contamination in accordance with specification limits. (Consult Parker CMC).
- **Distribution Terminals/Hubs**
 - For use on receipt and outbound supply. Also to provide filtration performance, tank cleanliness and product quality checks.
- **Storage**
 - Settling times can be reduced by monitoring with the ACM by ensuring that levels of dispersed contamination are below acceptable levels.
- **Airport Fuel Farm**
 - Monitoring of fuels into storage, through the fuel farm, hydrant system and during uplift into wing.
- **Pipeline Commissioning**
 - Fast real time monitoring of pipelines following pigging and cleaning processes.
- **Oil and Gas Platforms**
 - Used to monitor the filtration performance, system cleanliness and quality of delivered product.



icountACM20 Z2

ATEX Approved Portable Particle Counter

Installation Details

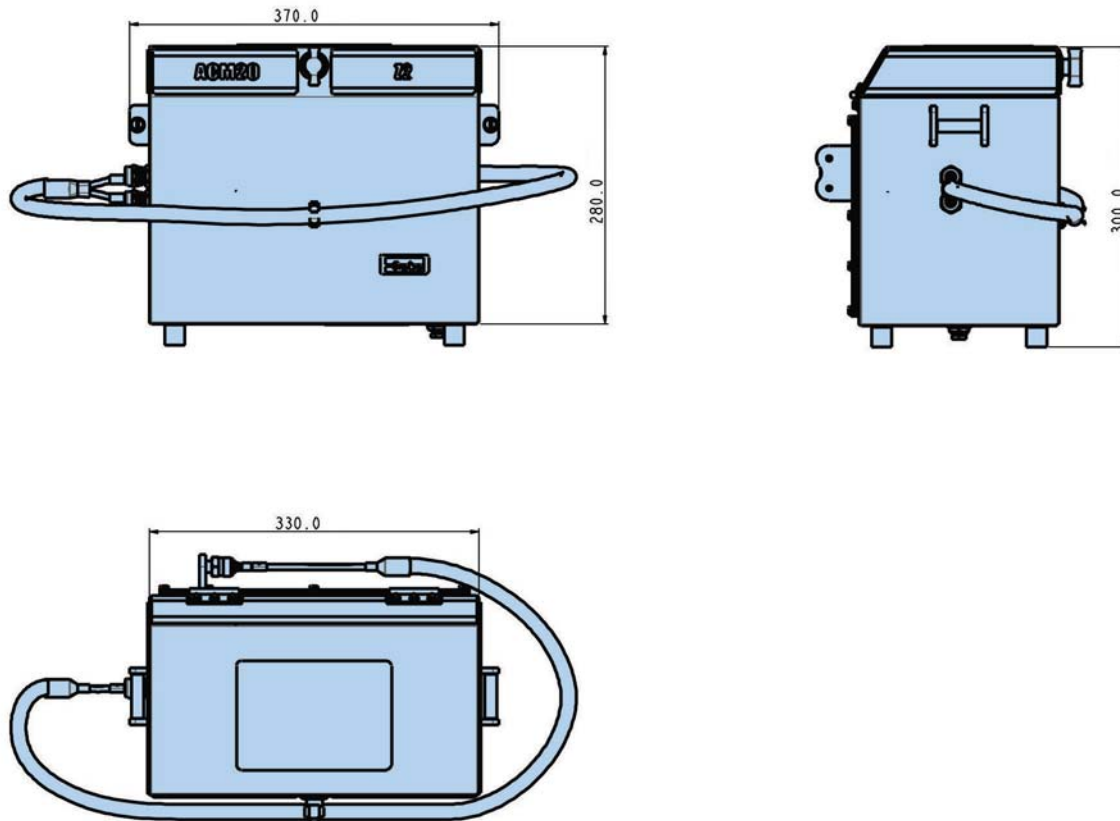

Ordering Information

Standard products table - icountACM20 Z2

Product number	Supersedes	Description
ACM202032UK	N/A	icountACM20 Z2 + online kit & UK battery charger
ACM202032US	N/A	icountACM20 Z2 + online kit & US battery charger
ACM202032EUR	N/A	icountACM20 Z2 + online kit & Euro battery charger
ACM202034UK		icountACM20 Z2 + online & lab kit + UK battery charger
ACM202034US		icountACM20 Z2 + online & lab kit + US battery charger
ACM202034EUR		icountACM20 Z2 + online & lab kit + Euro battery charger
ACC6NE023	B84647	UK battery charger
ACC6NE025	B84652	US battery charger
ACC6NE024	B84653	Euro battery charger
ACC6NE027	B84650	2m process cable assembly
ACC6NE006	B84816	Parsmart downloader software
ACC6NE028	P843066	Carry case
ACC6NW003	B84746	Bottle assembly
ACC6NE029	B84745	Throttle kit
ACC6NE001	B84645	Millipore adaptor assy

Applications in hydraulics

OFFSHORE

Solutions in the offshore industry.

In addition, the icountACM20 Z2 can be used in many hydraulic system applications as detailed below.

In many industries, worker awareness needs to be maintained at a high level to ensure the safety of their operation. This is particularly relevant to offshore oil-drilling and gas-drilling crews, given the interactive and hazardous nature of their work. The Zone II ACM portable particle analyser is a tried and tested technology designed, proven and approved as a fluid contamination monitor that crews are using and trusting in such hazardous and demanding environments.

- Certified to CE Ex II 3 G Ex nR/nL IIC T6
- Can be used in explosive and hazardous areas, including Offshore and Mining.
- Primary Output. Six cumulative particle size channels ranging from $\geq 4\mu\text{m}(c)$ to $\geq 30\mu\text{m}(c)$ and numbers per ml in accordance with ISO4406-1999.



REFINERIES



icountACM20 Z2 – operational in oil refineries and fuel fields.

Already operational in oil refineries and designed to be used inside commercial airfield fuel locations and at the point of upload of fuel into the aircraft, icountACM20 Z2 has an impressive success record in this approval sensitive area of operation.

With a number of safety features designed in as operational standards, the icountACM20Z2 can be taken to the point of use, connected in moments and reporting in little more than 2 minutes to ISO approved standards.

- Assembled in an approved and certified stainless steel enclosure to comply with ATEX Directive 94/9/EC and EN50 021 requirements.
- 'A' Class product defined for the aviation market.
- Designed for on-line operation, connecting to the process line via existing Millipore™ fittings, already in use for other industry equipment.

QUARRYING

Applications in other hazardous environments.

- Railroad equipment manufacturer - Warranty protection.
- Power generation stations - Preventative maintenance.
- Mobile equipment - Roll-off cleanliness testing.
- Mining operations - Service tool.
- Steel mills - Preventative maintenance.



icountACM20 Z2

ATEX Approved Portable Particle Counter

Average Particle Counts in AV System

The table below gives estimated counts found in a typical aviation fuel distribution system, and is given as guidance, in which API/EI filtration equipment is installed.

Receipt into Microfilter
Expect 2,500 counts per ml or cleaner @ 4μ(c)

MF



Receipt into FWS (After MF)
Expect 500 counts per ml or cleaner @ 4μ(c)

FWS



Receipt into Storage (After FWS/MF)
Expect 100 counts per ml or cleaner @ 4μ(c)

Airport storage



FWS out of storage
Expect 500 counts per ml or cleaner @ 4μ(c)

FWS



After FWS into Hydrant
Expect 100 counts per ml or cleaner @ 4μ(c)

To Hydrant/Refueller



After Monitor Into Aircraft
Expect 100 counts per ml or cleaner @ 4μ(c)



Receipt into Microfilter		ISO Code - 4406 1999
	High Count	High Count Code
≥4μ(c)	2,500	18
≥6μ(c)	350	15
≥14μ(c)	10	10

Receipt into FWS (After MF)		ISO Code - 4406 1999
	High Count	High Count Code
≥4μ(c)	500	16
≥6μ(c)	50	13
≥14μ(c)	5	9

Receipt into Storage (After FWS/MF)		ISO Code - 4406 1999
	High Count	High Count Code
≥4μ(c)	100	14
≥6μ(c)	10	10
≥14μ(c)	1	7

FWS Out of Storage		ISO Code - 4406 1999
	High Count	High Count Code
≥4μ(c)	500	16
≥6μ(c)	50	13
≥14μ(c)	5	9

After FWS Into Hydrant		ISO Code - 4406 1999
	High Count	High Count Code
≥4μ(c)	100	14
≥6μ(c)	10	10
≥14μ(c)	1	7

After Monitor Into Plane		ISO Code - 4406 1999
	High Count	High Count Code
≥4μ(c)	100	14
≥6μ(c)	10	10
≥14μ(c)	1	7

Note: Figures will vary from location to location.

Key: MF=Microfilter (API/EI 1590)

FWS=Filter Water Separator (API/EI 1581)

icountPD

Online Particle Detector

For mineral oil, aggressive fluids or fuels



Independent monitoring of system contamination trends

The icountPD Particle Detector from Parker represents the most up to date technology in particle detection. The design dynamics, attention to detail and moulding compactness of the permanently mounted, on-line particle detector module, combined with on-board, laser based, leading-edge technology, brings to all industries a truly revolutionary, particle detector as a remarkable cost effective market solution to fluid management and contamination control.



icountPD for mineral oil applications

Contact Information:

Parker Hannifin
Hydraulic Filter Division Europe

**European Product
Information Centre**
Freephone: 00800 27 27 5374
**(from AT, BE, CH, CZ, DE, EE, ES,
FI, FR, IE, IT, PT, SE, SK, UK)**
filtrationinfo@parker.com

www.parkerhfde.com

Product Features:

- Independent monitoring of system contamination trends.
- Warning LED or digital display indicators for Low, Medium and High contamination levels.
- Visual indicators with power and alarm output warnings.
- Moisture %RH indicator (optional).
- Cost effective solution to prolong fluid life and reduce machine downtime.
- M12 8 pin or Deutsch Connector options.
- Continuous performance for prolonged analysis.
- Fuel, Hydraulic and phosphate Ester fluid compatible construction.
- Self diagnostic software.
- Full PC/PLC integration technology such as:- RS232 and 0-5Volt, 4-20mA, CAN(J1939) (Contact Parker for other options).
- Set up and Data logging support software included.

icountPD

Online Particle Detector

Features & Benefits

Diagnostic Self Check Start-up Time:

Customer selectable 5-900 seconds

Measurement Period:

5 to 180 seconds

Reporting interval through RS232:

0 to 3600 seconds

Digital -/LED display update time:

Every second

Limit Relay Output:

Changes occur +/- 1 ISO code at set limit (Hysteresis ON) or customer set (Hysteresis OFF)

Particle / % RH Output Signal:

Continuous

Principle of operation:

Laser diode optical detection of actual particulates.

Reporting Codes:

ISO 7 – 21, NAS 0 – 12, (AS 00 – 12 Contact Parker)

icount will also report less than ISO 7, subject to the statistical uncertainty defined in ISO4406:1999, which is shown in the RS232, reporting results as appropriate e.g ">6"

Calibration:

By recognised on-line methods, confirmed by the relevant International Standard Organisation procedures.

Calibration Recommendation:

12 months

Performance:

+/- 1 ISO Code (Dependant on stability of flow)

Reproducibility / Repeatability:

Better than 1 ISO Code

Power Requirement:

Regulated 9 to 40Vdc

Maximum Current Draw:

150mA

Hydraulic Connection:

Mineral M16x2 test Points

Aggressive: 5/8" BSF test Points

Fuel: No test Points 1/8 BSP (Female) Ports (Plugged)

Required Flow Range through the icountPD:

40 to 140 ml/min (Optimum Flow = 60ml/min)

Online Flow Range via System 20 Inline Sensors (Hydraulic systems only):

Size 0 = 6 to 25 l/min - (Optimum Flow = 15 l/min)

Size 1 = 24 to 100 l/min - (Optimum Flow = 70 l/min)

Size 2 = 170 to 380 l/min - (Optimum Flow = 250 l/min)

Required Differential Pressure across Inline Sensors:

0.4 bar (Minimum)

Viscosity Range:

1-500 cSt

Temperature:

Operating Environment -20°C to +60°C (-4°F to +140°F)

Storage -40°C to +80°C (-40°F to +176°F)

Operating Fluid 0°C to +85°C (+32°F to +185°F)

Working pressure:

2 to 420 bar (30-6000 PSI)

Moisture sensor calibration (Not offered with the fuel version):

±5% RH (over compensated temperature range of +10°C to +80°C) (+50°F to +176°F)

Operating humidity range:

5% RH to 100% RH

Moisture sensor stability:

±0.2% RH typical at 50% RH in one year

Certification:

IP66 rated

EMC/RFI – EN61000-6-2:2001

EN61000-6-3:2001

Materials:

User friendly Abs construction.

Stainless Steel hydraulic block.

Dimensions:

182mm x 155mm x 86mm (7.2" x 6.1" x 3.4")

Weight:

1.3kg (2.9lb)

Seals:

Mineral: Fluorocarbon. Aggressive: EPDM. Fuel: Fluorocarbon.

icountPD for use with aviation fuels

Field Data - Major International Airport

First 3 measurements represent fuel from a previous cargo followed by a regular clean delivery, thus demonstrating the range of fuel cleanliness being experienced at this particular location.

	>4µ	>6µ	>14µ	>21µ	>4µ	>6µ	>14µ	>21µ
Test 1	81058.3	62126.1	17817.6	6066.2	Test 5	1226.1	261.5	2.4
Test 2	87834.5	74763.0	35454.1	18044.4	Test 6	1085.7	210.9	1.3
Test 3	51383.4	32796.9	4424.8	1213.4	Test 7	1037.9	198.7	1.3
Test 4	1593.3	422.7	9.6	1.7				

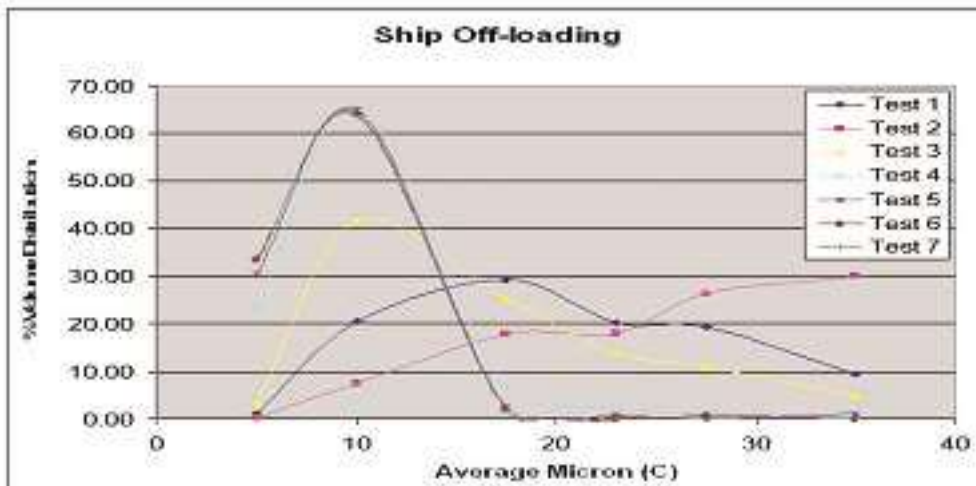

icountPD for use with aviation fuels

Dimensions / Installation Details

mm
(inches)

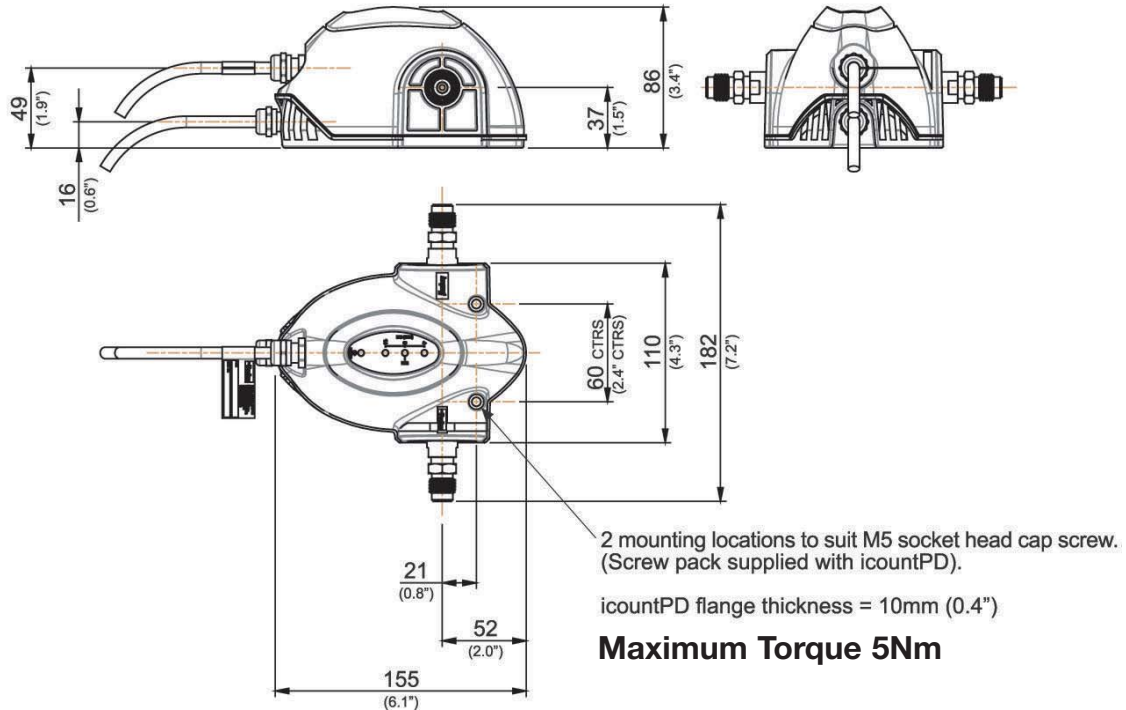

Typical Applications

- **Mobile Equipment**

- Earth Moving Machinery
- Harvesting
- Forestry
- Agriculture

Monitoring of the hydraulics, enabling the vehicles to function to their best capability under load conditions through pistons, servo valves, control rams and gear pumps.

- **Industrial Equipment**

- Production Plants
- Fluid Transfers
- Pulp & Paper
- Refineries

To monitor the cleanliness of the equipment throughout the production line, from the machine tool controlled hydraulics through to contamination of fluid transfer. Ensuring the integrity of the fluid is maintained throughout the refining process.

- **Power Generation**

- Wind Turbines
- Gearboxes
- Lubrication Systems

With continuous monitoring the optimum level is achieved in the least amount of time.

- **Maintenance**

- Test Rigs
- Flushing Stands

To increase efficiency of your equipment by continuously monitoring the cleanliness level of the hydraulic fluid.

- **Fuel Contamination Detection**

- Fuel Storage Tanks
- Vehicle fuel tanks
- Uploading fuel into an aircraft

24/7 detection of particulate levels in most fuels including aviation fuel - Jet A-1 fuel specification.

icountPD

Online Particle Detector

M12 Communication cable: wiring configuration

M12 Communication cable

Pin	4-20mA option connections	0-5v/0-3v option connections
1	NOT USED	NOT USED
2	RS232 Ground (Pin 5**)	RS232 Ground (Pin 5**)
3	Channel A, ISO 4µm(c)*	Channel A, ISO 4µm(c)*
4	Channel B, ISO 6µm (c)* or NAS (if selected)	Channel B, ISO 6µm (c)* or NAS (if selected)
5	RS232 Receive (Pin 3**)	RX232 Receive (Pin3**)
6	RS232 Transmit (Pin 2**)	RS232 Transmit (Pin 2**)
7	Moisture sensor channel (if fitted)	Moisture sensor channel (if fitted)
8	Channel C, ISO 14µm (c)*	Channel C, ISO 14µm (c)*

Important Note: It is the responsibility of the end user to ensure that the cable's braided screen is terminated to a suitable earth bonding point.

* Optional – refer to the 'IcountPD part number specifier' section in this manual.

** A standard USB serial adaptor can be used with the recommended 9-way D-type connector to convert RS232 to USB.

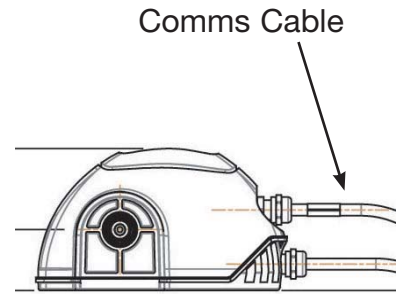

Limit relay alarm levels

The IcountPD can be specified with a built-in limit switch relay which can be triggered when a preset alarm level is reached. The relay contacts can be used to switch on or off an external device.

M12 Supply and Relay (if fitted) cable

Pin	Current loop options connections	0-5v/0-3v option connections
1	Product supply 9-40Vdc	Product supply 9-40Vdc
2	4-20mA Supply 12-20Vdc	0-5 / 0-3V Supply 12-24Vdc
3	Relay (Normally Closed)***(if fitted)	Relay (Normally Closed)***(if fitted)
4	Relay (Normally Open)***(if fitted)	Relay (Normally Open)***(if fitted)
5	NOT USED	NOT USED
6	NOT USED	0-5V / 0-3V Supply 0 Vdc
7	Main supply 0Vdc	Product supply 0Vdc
8	Relay (Common)***(if fitted)	Relay (Common)***(if fitted)

Note: If the moisture sensor is fitted without either option then the output is RS232.

Parker Hannifin recommend that the mating M12 connector cables are screened. These cables are available from Parker Hannifin – ordering information section.

*** Optional – refer to ordering information section.

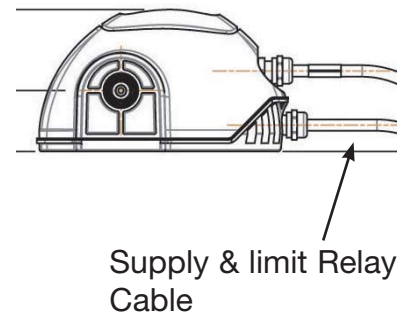

(Limit Relay Wiring Instructions)

NORMALLY OPEN

NORMALLY CLOSED

COMMON

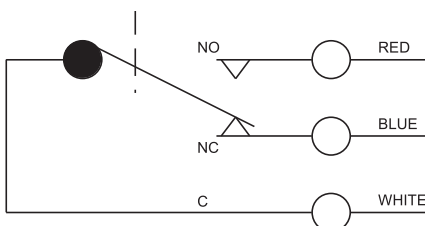

Variable mA output settings

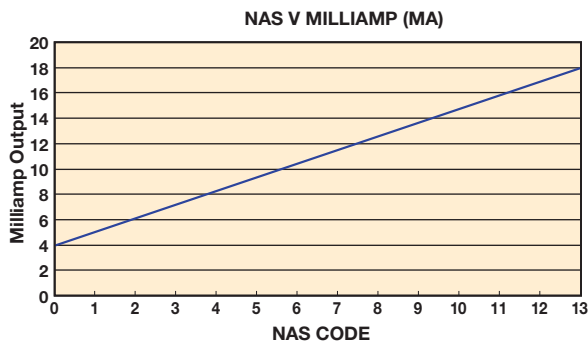
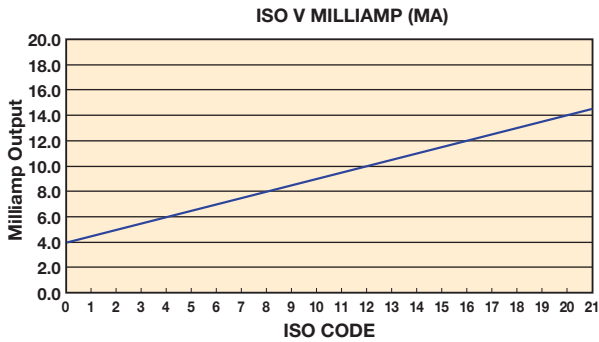

The following table can be used to equate the analogue output to an ISO or NAS Code.

Example ISO code 12 is equal to 10mA

mA	ISO	mA	NAS
4.0	0	4	00
4.5	1	5	0
5.0	2	6	1
5.5	3	7	2
6.0	4	8	3
6.5	5	9	4
7.0	6	10	5
7.5	7	11	6
8.0	8	12	7
8.5	9	13	8
9.0	10	14	9
9.5	11	15	10
10.0	12	16	11
10.5	13	17	12
11.0	14	18	**
11.5	15	19	**
12.0	16	20	ERROR
12.5	17		
13.0	18		
13.5	19		
14.0	20		
14.5	21		
15.0	**		
15.5	**		
16.0	**		
16.5	**		
17.0	**		
17.5	**		
18.0	**		
18.5	**		
19.0	OVERRANGE		
19.5	OVERRANGE		
20.0	ERROR		

The following table can be used to equate the analogue output to an ISO or NAS Code.

Example ISO code 12 is equal to 10mA

4-20mA output settings

ISO Setting

mA current = (ISO Code / 2) + 4 eg. 10mA = (ISO 12 / 2) + 4

or

ISO Code = (mA current - 4) * 2 eg. ISO 12 = (10mA - 4) * 2

NAS Setting

mA current = NAS Code + 5 eg. 15mA = NAS 10 + 5

or

NAS Code = mA current - 5 eg. NAS 10 = 15mA - 5

Variable voltage output settings

The variable voltage output option has the capability of two different voltage ranges: a 0–5Vdc range as standard, and a user-selectable 0–3Vdc range. The 'Full list of commands' on how to change the voltage output, are available from Parker.

The following tables can be used to relate the analogue output to an ISO or NAS code.

For example, in a 0–5Vdc range, ISO code 16 is equal to an output of 3.5Vdc. In a 0–3Vdc range, ISO code 8 is equal to an output of 1.0Vdc.

Table relating ISO codes to Voltage output

ISO	Err	0	1	2	3	4	5	6	7	8	9	10	11
0–5Vdc	<0.2	0.3	0.5	0.7	0.9	1.1	1.3	1.5	1.7	1.9	2.1	2.3	2.5
0–3Vdc	<0.15	0.2	0.3	0.4	0.5	0.6	0.7	0.8	0.9	1.0	1.1	1.2	1.3

cont.

ISO	12	13	14	15	16	17	18	19	20	21	22	Err
0–5Vdc	2.7	2.9	3.1	3.3	3.5	3.7	3.9	4.1	4.3	4.5	4.7	>4.8
0–3Vdc	1.4	1.5	1.6	1.7	1.8	1.9	2.0	2.1	2.2	2.3	2.4	>2.45

Table relating NAS codes to Voltage output

ISO	Err	00	0	1	2	3	4	5	6	7	8	9	10	11	12	Err
0–5Vdc	<0.4	0.6	0.9	1.2	1.5	1.8	2.1	2.4	2.7	3.0	3.3	3.6	3.9	4.2	4.5	>4.6
0–3Vdc	<0.2	N.S.	0.3	0.5	0.7	0.9	1.1	1.3	1.5	1.7	1.9	2.1	2.3	2.5	2.7	>2.8

icountPD

Online Particle Detector

Digital display parameters (ISO 4406/NAS 1638)

Start up

1. Once the icountPD has been connected to a regulated power supply, the product logo is displayed for approximately five seconds as the icountPD performs a self system diagnostic check.
2. The icountPD then automatically starts monitoring using factory default test parameters.



Digital display indication

The digital display will show the actual measured codes, the channel (μ) size and the user definable limits. Note that the channel size and limits will alternate between the two.

The Moisture Sensor reading (%RH) will also be shown – if the Moisture Sensor option is fitted.

The order of trigger for both the codes and Moisture Sensor option is:

- Solid digit(s) = code(s) that are at or below the set point (limit)
- Flashing digit(s) = code(s) that are above the set point (limit)

The display for ISO4406 and NAS1638 are identical.

Error detection:

In the unlikely event of a error occurring, the digital display on the icountPD will simply display the actual error code only – i.e. ERROR 13 (A full list of error codes are detailed in the icountPD User Manual).

Moisture sensor output settings

The Moisture Sensor is an option that can be included when ordering the icountPD.

The Moisture Sensor reports on the saturation levels of the fluid passing through the icountPD sensing cell. The output is a linear scale, reporting within the range of 5% saturation to 100% saturation.

Table relating Saturation levels in the sensing cell to icountPD outputs

Saturation	4–20mA	0–3Vdc	0–5Vdc
5%	4.8	0.15	0.25
25%	8	0.75	1.25
50%	12	1.50	2.50
75%	16	2.25	3.75
100%	20	3.00	5.00

Auxiliary Flow Device - P/N S840074

The pressure compensated, Flow control device (Part Number S840074) has been developed to give the icountPD user greater flexibility. The Flow control device will enable testing where flow ranges are outside the icountPD specifications (40 – 140 ml/min), or where pipe diameters do not allow the icountPD to be installed.

The Flow control device fits onto the downstream (outlet) side of the icountPD, connecting through a manifold block, via a self-sealing quick connection test point and is fitted with a differential pressure valve.

This Flow control device automatically compensates for pressure and viscosity changes, whilst maintaining its setting even as the workload changes.

Simply position the valve to match the viscosity of the oil you are testing.

The chart can be used to determine the valve position:

Auxiliary Flow Device - P/N ACC6NN019

This simple to use flow control device fits onto the downstream (outlet) side of the icountPD and is fitted with a differential pressure valve that adjust the system flow to a range inside the icountPD specifications. Contact Parker for more details.

icount PD – Oil Cleanliness Indicator (icount PD OCI)

- New and under development in the detection of contaminates distribution in various Aviation fuels.
- Portable monitoring tool providing fluid qualification to ISO 4406:1999 standards.
- Supplements the icount ACM20 product portfolio.
- Quick, simple to use monitoring tool for sampling fluids from containers, fuel bunkers and holding tanks.
- Field solution to Laboratory methods for the detection of solid contamination and free water inference.



Note: use this chart to determine the valve position:

Valve Position	cSt Range
3	up to 100
3.8	90 - 200
4.2	190 - 320
5	310 - 500

Example:

If the fluid you wish to analyse has a viscosity of 50cSt under normal operating conditions then the control knob on the Flow Control Device should be set to valve position '3'

The flow device will now automatically control the flow rate through the icountPD to within its working range of 40-140ml/min.

Note: The Flow control device will still operate correctly even with the high pressure side at 200bar and the return back to an open system of 0 bar (DP = 200bar)



P/N ACC6NN019



icountPD

Online Particle Detector

Hydraulic Connection Diagram

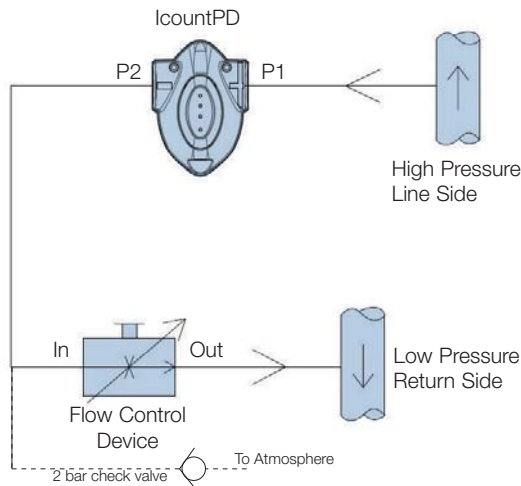

Dimensions

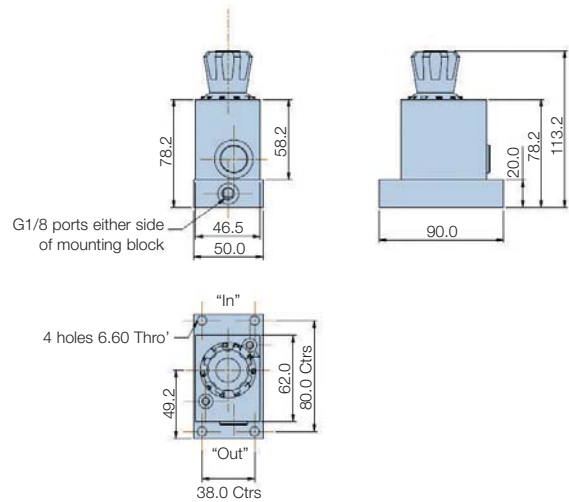

Actuator

Mounting Type

Mounting position

Weight

Fluid Temperature

Ambient storage temperature

Viscosity range

Differential pressure range

Maximum pressure

Flow direction

Port thread detail

Internal Seals

Manual flow rate adjustable via control knob

4 off mounting holes to suit M6 screws (not supplied)

Any

1.7kg (3.7lb)

5°C to +80°C (+41°F to 176°F)

-20°C to +40°C (-4°F to +104°F)

20cSt to 500cSt (If lower than 20cSt contact Parker)

5 to 315 bar

315 bar

'IN' to 'OUT' flow control function

1/8" BSP (test points not supplied)

Fluoroelastomer



This application shows uploading fuel into an aircraft with the icountPD in use to monitor as a 'go/no go' device.

Communication Options

The icountPD may be configured using the icountPD Setup Utility. For more direct control of the device using its communications protocol, you may also use the Microsoft Windows® HyperTerminal program, but note that this program is not currently supplied with the Windows Vista™ operating system. These two ways of communicating with icountPD are described in the following section.

icontainsPD Setup Utility software (supplied)

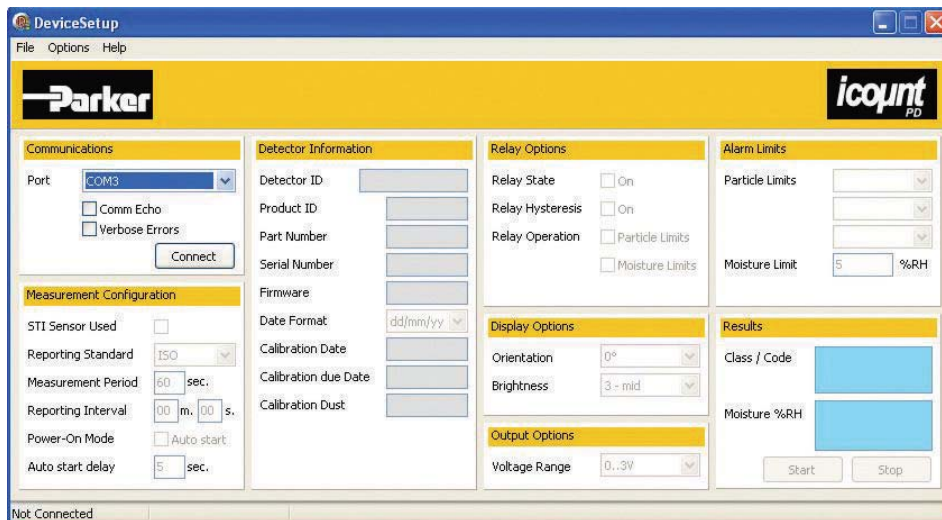

Communication Protocol

The Communication protocol for the serial communication link is to be used with **Microsoft Windows HyperTerminal**. The settings are as follows:

Baud rate	9600
Data bits	8
Parity	None
Stop bits	1
Flowcontrol	None

The commands used with this product are made up of Read, Set and Start / Stop commands.

- Set commands allow the value or values of parameters to be set
- Read commands allow the value or values or parameters to be read
- Start/Stop allows the user to start and stop tests.

Example:

[SDF dd/mm/yy] - sets the date format.

[RDF] - reads the product date format.

All commands are sent in ASCII characters, and the protocol accepts both upper and lower case characters as the examples below:

SDF

SdF

Note: A full list of commands are detailed in the user manual

icountPD

Online Particle Detector

Ordering Information

Standard Products Table

Part number	Fluid type	Calibration	Display	Limit relay	Communications	Moisture sensor	Cable connector kit	Future option
IPD12212130	Mineral	MTD	LED	No	RS232 / 4-20mA	No	M12 - 8 pin	N/A
IPD12212230	Mineral	MTD	LED	No	RS232 / 4-20mA	Yes	M12 - 8 pin	N/A
IPD12222130	Mineral	MTD	LED	Yes	RS232 / 4-20mA	No	M12 - 8 pin	N/A
IPD12222230	Mineral	MTD	LED	Yes	RS232 / 4-20mA	Yes	M12 - 8 pin	N/A
IPD12312130	Mineral	MTD	Digital	No	RS232 / 4-20mA	No	M12 - 8 pin	N/A
IPD12312230	Mineral	MTD	Digital	No	RS232 / 4-20mA	Yes	M12 - 8 pin	N/A
IPD12322130	Mineral	MTD	Digital	Yes	RS232 / 4-20mA	No	M12 - 8 pin	N/A
IPD12322230	Mineral	MTD	Digital	Yes	RS232 / 4-20mA	Yes	M12 - 8 pin	N/A

Product Configurator

Key	Fluid type	Calibration	Display	Limit relay	Communications	Moisture	Cable connector kit
IPD	1 Mineral	1 ACFTD	1 None	1 No	1 RS232	1 No	00 No
IPDZ	2 Phosphate ester	2 MTD	2 LED	2 Yes	2 RS232 / 4-20mA	2 Yes	10 Deutsch 12-pin DT Series connector
IPDR	3 Aviation fuel (4 channel)	3 AS4059	3 Digital		3 RS232 / 0-5V		30 M12, 8 pin plug connector
			4 GSM		4 RS232 / RS485		
					5 RS232/CAN-bus		

Accessories

Part number		Description
Mineral fluids	Aggressive fluids	
ACC6NE003	ACC6NN002	1 metre hose length
ACC6NN003	ACC6NN004	2 metre hose length
ACC6NN005	ACC6NN006	5 metre hose length
ACC6NN007	ACC6NN008	1/4" BSP fitting
ACC6NN009	ACC6NN010	1/8" BSP fitting
ACC6NN011	ACC6NN012	1/8" BNPT fitting
SPS2021	SPS2061	Single point sampler
S840074	Contact Parker	Flow control device
ACC6NN019	Contact Parker	Flow control valve
ACC6NN013		12 volt regulated power supply
ACC6NN014	Contact Parker	2 x 5 metre M12 - 8 pin cable kit*
ACC6NN016		Deutsch Connector Kit
ACC6NN017		RS232 To USB cable kit
ACC6NN018		M12 - 8 pin to RS232 engineers tool

* M12 Cable kit consists of two 5 metre cables to enable all output options (Communications cable and Relay/Power Supply cable)

** Note that the aggressive fluid hoses are provided as a single hose, not in pairs.

Part number	Supersedes	Size	Flow range l/min	Fluid type	Port threads	Reverse Flow capability
STI0144100	STI.0144.100	0	6-25	Mineral	3/8	Yes
STI1144100	STI.1144.100	1	20-100	Mineral	3/4	Yes
STI2144100	STI.2144.100	2	80-380	Mineral	1 1/4	Yes
STI0148100	STI.0148.100	0	6-25	Aggressive	3/8	Yes
STI1148100	STI.1148.100	1	20-100	Aggressive	3/4	Yes
STI2148100	STI.2148.100	2	80-380	Aggressive	1 1/4	Yes
STS5117210	STS.5117.210	1	20-100	Mineral	3/4	No
STS5217210	STS.5217.210	2	80-380	Mineral	1 1/4	No

icountPD Z2

ATEX Approved Online Particle Detector



For use in explosive and hazardous areas

The icountPD Particle Detector from Parker represents the most up to date technology in solid particle contamination analysis. This compact, permanently mounted laser-based ATEX approved particle detector module is designed for use in Zone 2 areas and is housed in a robust Stainless Steel IP69K approved enclosure that provides a cost effective solution to fluid management and contamination control.



Contact Information:

Parker Hannifin
Hydraulic Filter Division Europe

European Product Information Centre
Freephone: 00800 27 27 5374
(from AT, BE, CH, CZ, DE, EE, ES, FI, FR, IE, IT, PT, SE, SK, UK)
filtrationinfo@parker.com

www.parkerhfde.com

Product Features:

- Independent monitoring of system contamination trends.
- Assembled in an approved and certified Stainless Steel enclosure to comply with ATEX Directive 94/9/EC.
- Can be used in explosive and hazardous areas.
- ATEX Zone 2.
- Certified to CE Ex II 3GD, Ex nA IIC T4 Gc, Ex tc IIIC Dc SIRA 09ATEX4340X and IECEx SIR 09.0137X (-30°C<Ta<+60°C).
- Moisture & %RH indicator (optional).
- Warning limit relay outputs for low, medium and high contamination levels.
- Continuous performance for prolonged analysis.
- Self diagnostic software.
- Full PC/PLC integration technology such as:- RS232 and 0-5Volt, 4-20mA, CAN(J1939) (Contact Parker for other options).
- Set up and Data logging support software included.



icountPD Z2

ATEX Approved Online Particle Detector



Features & Benefits

Diagnostic Self Check Start-up Time:

Customer selectable 5-900 seconds

Measurement Period:

5 to 180 seconds

Reporting interval through RS232:

0 to 3600 seconds

Limit Relay Output:

Changes occur +/- 1 ISO code at set limit (Hysteresis ON) or customer set (Hysteresis OFF)

Particle / % RH Output Signal:

Continuous

Principle of operation:

Laser diode optical detection of actual particulates.

Reporting Codes:

ISO 7 – 21, NAS 0 – 12, (AS 00 – 12 Contact Parker)

icount will also report less than ISO 7, subject to the statistical uncertainty defined in ISO4406:1999, which is shown in the RS232, reporting results as appropriate e.g “>6”

Calibration:

By recognised on-line methods, confirmed by the relevant International Standard Organisation procedures.

Calibration Recommendation:

24 months

Performance:

+/- 1 ISO Code (Dependant on stability of flow)

Reproducibility / Repeatability:

Better than 1 ISO Code

Power Requirement:

Regulated 9 to 40Vdc

Maximum Current Draw:

150mA

Hydraulic Connection:

Size: 066

Connection: EO 24 cone end

Required Flow Range through the icountPD:

40 to 140 ml/min (Optimum Flow = 60ml/min)

Online Flow Range via System 20 Inline Sensors (Hydraulic systems only):

Size 0 = 6 to 25 l/min - (Optimum Flow = 15 l/min)

Size 1 = 24 to 100 l/min - (Optimum Flow = 70 l/min)

Size 2 = 170 to 380 l/min - (Optimum Flow = 250 l/min)

Required Differential Pressure across Inline Sensors:

0.4 bar (Minimum)

Viscosity Range:

1-500 cSt

Temperature:

Operating Environment -30°C to +60°C (-22°F to +140°F)

Storage -40°C to +80°C (-40°F to +176°F)

Operating Fluid +5°C to +80°C (+41°F to +176°F)

Working pressure:

2 to 420 bar (30-6000 PSI)

Moisture sensor calibration (Not offered with the fuel version):

±5% RH (over compensated temperature range of +10°C to +80°C (+50°F to +176°F))

Operating humidity range:

5% RH to 100% RH

Moisture sensor stability:

±0.2% RH typical at 50% RH in one year

Certification:

IP69K rating

EMC/RFI – EN61000-6-3:2007

EN61000-6-2:2005

Materials:

Stainless Steel case construction.

Stainless Steel hydraulic block.

Dimensions:

260mm x 114mm x 110mm

Weight:

2.6kg

Seals:

Fluorocarbon seals.

Ordering Information

Product Configurator

Key	Fluid type	Calibration	Display	Limit relay	Communications	Moisture	Cable connector kit
IPD	1 Mineral	1 ACFTD	1 None	1 No	1 RS232	1 No	00 No
IPDZ	2 *Phosphate ester	2 MTD	2 LED	2 Yes	2 RS232 / 4-20mA	2 Yes	10 Deutsch 12-pin DT Series connector
IPDR	3 Aviation fuel (4 channel)	3 AS4059	3 Digital		3 RS232 / 0-5V		30 M12, 8 pin plug connector
			4 GSM		4 RS232 / RS485		
					5 RS232/CAN-bus		

*Consult Parker Filtration

Standard Products Table

Part number	Fluid type	Calibration	Display	Limit relay	Communications	Moisture sensor	Cable connector kit
IPDZ12122230	Mineral	MTD	None	Yes	RS232 / 4-20mA	Yes	M12, 8 pin plug connector
IPDZ12121230	Mineral	MTD	None	Yes	RS232	Yes	M12, 8 pin plug connector
IPDZ12123230	Mineral	MTD	None	Yes	RS232 / 0-5V	Yes	M12, 8 pin plug connector
IPDZ12125230	Mineral	MTD	None	Yes	RS232 / CAN-bus	Yes	M12, 8 pin plug connector

Accessory Part Numbers

Description	Part Number
Single Point Sampler	SPS2021
External flow device	S840074
Power supply	ACC6NN013
2 x 10 metre M12, 8-pin plug and socket Ultrat cable kit	ACC6NN021
RS232 to USB converter	ACC6NN017

Note: For System 20 Sensor part numbers see page 380.



icountBS

Bottle Sampler



In the lab or in the field monitoring

Parker Filtration's icountBS is a unique and complete solution providing customers with laboratory fluid bottle sampling using proven on-board, laser based technology. icountBS is a next generation product from Parker's fluid particle analysis and monitoring programme and provides an effective alternative to external laboratory services.



Contact Information: Product Features:

Parker Hannifin
Hydraulic Filter Division Europe

**European Product
Information Centre**
Freephone: 00800 27 27 5374
**(from AT, BE, CH, CZ, DE, EE, ES,
FI, FR, IE, IT, PT, SE, SK, UK)**
filtrationinfo@parker.com

www.parkerhfde.com

- Quick sample bottle analysis with variable test time options from 15 seconds and volume capacities from 10ml.
- Repeatable and re-producible result performance to ISO4406:1999 and NAS1638 particle count distributions.
- On-board compressor and 'shop' air capability.
- Environmentally controlled front-loading bottle chamber.
- Design concept allowing for portability. DC and rechargeable battery pack power option built in.
- 6 fixed channel size analysis.
- Fluid resistant touch type screen panel.
- On-board thermal printer.
- 500 test memory (fully downloadable).

The complete solution - industrial design combined with state of the art technology

The icountBS - Bottle Sampler from Parker with its innovative industrial design has been developed for customers looking for state of the art technology, attention to detail and the compactness of a permanent laboratory particle analysis model.

Combine this with on-board, laser based, leading edge technology to bring to all industries a truly revolutionary Particle Counter.

The icountBS is a product from the next generation of Parker's fluid particle analysis and monitoring innovations.

The IBS features an easy to use interactive touch screen, environmentally controlled pressurized bottle chamber for air bubble suppression via an internal compressor pump, with automated door locking mechanism, sample tube cleaning sleeve minimizing contamination cross over, and an internal thermal printer.

The icountBS benefits from Parkers knowledge and experience of providing bottle analysis equipment to the market over the last 20 years.

This experience comes from selling market leading innovative solutions and by having front line condition monitoring products for all sectors of fluid analysis opportunities. The unit was at every stage developed with the customers voice in mind.





icountBS - Bottle Sampler Features & Benefits

- Quick sample bottle analysis with variable test time options from 15 seconds and volume capacities from 10ml.
- Repeatable and re-producible result performance to ISO4406:1999 and NAS1638 particle count distributions. For other calibration standards consult Parker CMC.
- On-board compressor and 'shop' air capability.
- Design concept allowing for portability. DC and rechargeable battery pack power options built in.
- Cost-effective and economical alternative solution to external laboratory services.
- 6 fixed channel size analysis.
- Fluid resistant touch type screen panel.
- Sample tube self cleaning sleeve minimizing contamination cross over.
- Internal thermal printer.

Analysing the test results

I have my results what do I do next?

Solid contaminants in fluid power systems vary in size, shape, form and quantity. The most harmful contaminants are normally between 6 microns and 14 microns. The ISO code is the preferred method of reporting quantity of contaminants.

The ISO code number corresponds to contamination levels relating to three sizes.

The first scale number represents the number of particles larger than

4µm(c) per 100 milliliters of fluid, the second number for particles larger than 6 µm(c) per 100 milliliters of fluid and the third number for particles larger than 14 µm(c) per 100 milliliters of fluid.

For example: An ISO code 20/18/14 indicates that there are between 500,000 and 1,000,000 particles larger than 4µm(c), and between 130,000 and 250,000 particles larger than 6 µm(c), and between 4,000 and 8,000 particles larger than 14µm(c).

icountBS reporting and data

In addition to the 'raw data' printout of ISO compliant data from the icountBS's on-board printer, icount Mini-lab offers the user the advantage of a 2-page report providing hard copy data on ISO/NAS individual counts and average contamination results.



FACT *Did you know the best human eye can only see particles above 40µ(c)?

Component Cleanliness Guide

Suggested acceptable contamination levels for typical hydraulic systems

Target contamination class to ISO 4406: 1999			Suggested maximum particle level			Sensitivity	Type of system	Typical components
4 µm(c)	6 µm(c)	14 µm(c)	4 µm(c)	6 µm(c)	14 µm(c)			
15	13	9	16,000	4,000	250	Super critical	Silt-sensitive control systems with very high reliability. Laboratory or aerospace	High performance servo valves
17	15	11	64,000	16,000	1,000	Critical	High performance servo and high pressure long life systems, e.g. aircraft, machine tools etc.	Industrial servo valves
18	16	13	130,000	32,000	4,000	Very important	High quality reliable systems. General machine requirements	Piston pumps, proportional valves, compensated flow controls
20	18	14	500,000	130,000	8,000	Important	General machinery and mobile systems. Medium pressure, medium capacity	Vane pumps, spool valves
21	19	15	1,000,000	250,000	16,000	Average	Low pressure heavy industrial systems, or applications where long life is not critical	Gear pumps, manual and poppet valves, cylinders
23	21	17	4,000,000	1,000,000	64,000	Main protection	Low pressure systems with large clearances	Ram pumps

Notes:

Tables have been generated by organisations in various industries.

Some of the tables are defined in cumulative counts, e.g. '>6µm' and others are represented as differential counts e.g. '6-14µm'.

All µm(c) refer to MTD distributions. All µm references will refer to ACFTD distributions.

All standards are in counts per 100ml and provide easy methods for converting particle counts into limits that are simple to interpret. By noting the requirements of the standard, particle counts can be accurately converted to contamination levels.

icountBS Product Specification

Principle of Operation	Laser based light obscuration
Calibration Dust	MTD or ACFTD
Dimensions	H=530 x W=190 (210 Door clearance) x D=410 (mm) H=20.9in x W=7.5in x 16.9in
Weight	18Kg
Mechanical Composition	Stainless steel 316, plated mild steel and aluminium
Plastics Composition	Precision polyurethane RIM mouldings and ABS plastic
Environmental Operating Temperature (Fully Tested)	+5°C to + 60°C (41°F to 140°F)
Operating % RH range	20 – 85% (Tested at 30°C, no condensation)
Storage Temperature	-40°C to + 90°C (-40°F to 194°F)
Storage RH range	10 – 90% (Tested at 30°C (86°F), no condensation)
Channel Sizes	MTD - $\geq 4\mu(c)$, $\geq 6\mu(c)$, $\geq 14\mu(c)$, $\geq 21\mu(c)$, $\geq 38\mu(c)$, $\geq 70\mu(c)$ ACFTD - $\geq 2\mu$, $\geq 5\mu$, $\geq 15\mu$, $\geq 25\mu$, $\geq 50\mu$, $\geq 100\mu$
Analysis Range	ISO 7 to 21, NAS 0 to 12
Contamination Standards	MTD - ISO 4406:1999 & NAS 1638 ACFTD - ISO 4406:1987, ISO 4406:1991 & NAS 1638 For further contamination standards consult Parker CMC
Calibration Standard	ISO MTD and ACFTD calibration to traceable ISO Standards. (Contact Parker CMC for further details).
Fluid Management	Maximum single sample = 100ml Minimum single sample = 10ml
Possible Test Configurations	User selectable from single test up to 5 tests per run (eg. 1x100ml up to 5 x50ml per run)
Pre-Test Flush Volume	Minimum = 10ml, Maximum = 100ml
Viscosity Range	1-400 cSt
Fluid Compatibility	Mineral oils, petroleum and hydrocarbon based fluids (consult manufacturer) and some esters (consult manufacturer).
Sample Bottle Size	Non specific. Max size = Ø75 (2.95in) x (H) 150 mm (5.9in). Max Volume = 250ml
Memory Storage	500 Tests (capacity warning after 450 tests)
Output Display	Backlight 256 Colour STN Transmissive
Output Display Resolution	320 x 3(R.G.B)(H) x 240(W) dots
Display Active Area	115(H) x 86(W) mm 4.5in (H) x 3.4 in (W)
Data Input	Via icon driven oil resistive touch screen
Printer	Thermal dot-line printing
Printer Paper	Ø50mm – (57mm x 25mm) Ø 1.97in – (2.24in x 0.98in)
Test Certification	Fully traceable Calibration & Certificate of Conformity
Power Supply	12Vdc@ 6.60Amps, 80 watts max.
Battery Power	2 Hours (recommended to be fully charged every 3 months)
Battery Stand-By Time	1 month (then 1 hour of operation)
Battery Fuse	6.3 Amps (anti-surge)
Air pressure Source	3.5 bar (51 PSI) internal Mini-compressor or 7 Bar (101 PSI) shop air



icountBS – Bottle Sampler Ordering Information

Key	Fluid Type		Calibration		Future Option		Future Option	Future Option	Future Option	Future Option	Power Supply Region	
IBS	1	Mineral	1	ACFTD	0	Lab Unit	0	0	1	0	0	UK
			2	MTD	1	Mini-lab Package					1	USA
											2	Europe

Key	Fluid Type		Calibration		Future Option		Future Option	Future Option	Future Option	Future Option	Power Supply Region	
IBS	1		2		0		0	0	1	0	0	
IBS	1		2		0		0	0	1	0	1	
IBS	1		2		0		0	0	1	0	2	

Part Number	Accessories
ACC6NW001	2 x 250ml sample bottle pack
ACC6NW002	100 x 250ml sample bottles (50 packs of 2)
ACC6NW003	Vapour / Waste bottle
ACC6NW005	Printer paper reel (x1)
ACC6NW006	UK power supply
ACC6NW007	USA power supply
ACC6NW008	European power supply
ACC6NW009	1 meter waste tube (Clear)
ACC6NW010	1 meter vapour hose (Blue)
ACC6NW011	USB memory stick
ACC6NW012	IBS CD manual
ACC6NW020	IBS transit case
SERMISCO49	Verification fluid

New icountABS coming soon

A new aviation fuel bottle sampler based on the icountBS with a method of operation which complies with IP564 methodology will be available soon.

Consult Parker for more details.



Introducing the icount 'Mini-lab' – The effective way of utilising your icountBS

How clean is your hydraulic system?

Contamination Control is only an oil sample away with our easy, 3-Step fluid analysis service.

Step 1

Obtain your sample of hydraulic oil.

Step 2

Take the 2 minute off-line oil sample test.

Step 3

View your results and run a report immediately.



Kit comprises: icountBS. Flat-pack trolley. 30 sample bottles. Optional Laptop/software/printer and cables

CMC Service Centres

Global Support for CMC products

Improving aftermarket support for condition monitoring products.

Parker's fluid Condition Monitoring Service Centres can be found currently in 10 locations around the globe, on almost every continent. Our experience and expertise in fluid condition monitoring and analysis ensure we are THE authority within our industry.

Each location offers first class aftermarket support for Condition Monitoring products, giving:

- Direct Contact for End Users.
- Quick and confident technical support to assist you in maintaining an efficient and trouble free monitoring process.

- Faster turn around for annual calibration verification, resulting in the product not having to come back to the country of manufacture.

Parker also offers on the icountACM20 laboratory unit:

- A six monthly field use verification sample for confident product performance.
- An extended two year warranty, giving confidence in product readiness.

Visit www.parkerhfde.com/condition/service/ to find your nearest location and contact details.

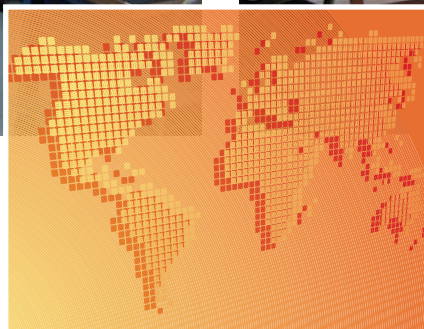

Parker returns policy and calibration procedure

Each product returned to an approved Parker Service Centre will have the following:

- **A visual inspection of all case components.**

If any components from the support case require replacing, please notify the Service Centre at the time of return.

Parker holds no responsibility for case contents and will only replace parts if required or deemed necessary.

- **An external inspection of the complete assembly.**

The particle counter will be thoroughly checked for signs of damage or misuse and if necessary an estimate of the cost of repair will be provided.

- **Full functionality test.**

This includes visual inspection of internal parts and their operation.

- **Replacement of any defective or damaged parts.**

No corrective work will be carried out on the product returned without the authorization from the end user.

- **Recalibration (with a Certificate valid for 12 months).**

Each unit is calibrated to the relevant ISO standards.

The recalibration procedure does not include the replacement of any damaged components that have been deemed defective through negligence or misuse.

Parker's Motion & Control Technologies

At Parker, we're guided by a relentless drive to help our customers become more productive and achieve higher levels of profitability by engineering the best systems for their requirements. It means looking at customer applications from many angles to find new ways to create value. Whatever the motion or control technology need, Parker has the experience, breadth of product and global reach to consistently deliver. No company knows more about motion and control technology than Parker.



AEROSPACE

Key Markets

- Aircraft engines
- Business & general aviation
- Commercial transports
- Land-based weapons systems
- Military aircraft
- Missiles & launch vehicles
- Regional transports
- Unmanned aerial vehicles

Key Products

- Flight control systems & components
- Fluid conveyance systems
- Fluid metering delivery & atomization devices
- Fuel systems & components
- Hydraulic systems & components
- Inert nitrogen generating systems
- Pneumatic systems & components
- Wheels & brakes



CLIMATE CONTROL

Key Markets

- Agriculture
- Air conditioning
- Food, beverage & dairy
- Life sciences & medical
- Precision cooling
- Processing
- Transportation

Key Products

- CO₂ controls
- Electronic controllers
- Filter driers
- Hand shut-off valves
- Hose & fittings
- Pressure regulating valves
- Refrigerant distributors
- Safety relief valves
- Solenoid valves
- Thermostatic expansion valves



ELECTROMECHANICAL

Key Markets

- Aerospace
- Factory automation
- Life science & medical
- Machine tools
- Packaging machinery
- Paper machinery
- Plastics machinery & converting
- Primary metals
- Semiconductor & electronics
- Textile
- Wire & cable

Key Products

- AC/DC drives & systems
- Electric actuators, gantry robots & slides
- Electrohydraulic actuation systems
- Electromechanical actuation systems
- Human machine interface
- Linear motors
- Stepper motors, servo motors, drives & controls
- Structural extrusions



FILTRATION

Key Markets

- Food & beverage
- Industrial machinery
- Life sciences
- Marine
- Mobile equipment
- Oil & gas
- Power generation
- Process
- Transportation

Key Products

- Analytical gas generators
- Compressed air & gas filters
- Condition monitoring
- Engine air, fuel & oil filtration & systems
- Hydraulic, lubrication & coolant filters
- Process, chemical, water & microfiltration filters
- Nitrogen, hydrogen & zero air generators



FLUID & GAS HANDLING

Key Markets

- Aerospace
- Agriculture
- Bulk chemical handling
- Construction machinery
- Food & beverage
- Fuel & gas delivery
- Industrial machinery
- Mobile
- Oil & gas
- Transportation
- Welding

Key Products

- Brass fittings & valves
- Diagnostic equipment
- Fluid conveyance systems
- Industrial hose
- PTFE & PFA hose, tubing & plastic fittings
- Rubber & thermoplastic hose & couplings
- Tube fittings & adapters
- Quick disconnects



HYDRAULICS

Key Markets

- Aerospace
- Aerial lift
- Agriculture
- Construction machinery
- Forestry
- Industrial machinery
- Mining
- Oil & gas
- Power generation & energy
- Truck hydraulics

Key Products

- Diagnostic equipment
- Hydraulic cylinders & accumulators
- Hydraulic motors & pumps
- Hydraulic systems
- Hydraulic valves & controls
- Power take-offs
- Rubber & thermoplastic hose & couplings
- Tube fittings & adapters
- Quick disconnects



PNEUMATICS

Key Markets

- Aerospace
- Conveyor & material handling
- Factory automation
- Life science & medical
- Machine tools
- Packaging machinery
- Transportation & automotive

Key Products

- Air preparation
- Brass fittings & valves
- Manifolds
- Pneumatic accessories
- Pneumatic actuators & grippers
- Pneumatic valves & controls
- Quick disconnects
- Rotary actuators
- Rubber & thermoplastic hose & couplings
- Structural extrusions
- Thermoplastic tubing & fittings
- Vacuum generators, cups & sensors



PROCESS CONTROL

Key Markets

- Chemical & refining
- Food, beverage & dairy
- Medical & dental
- Microelectronics
- Oil & gas
- Power generation

Key Products

- Analytical sample conditioning products & systems
- Fluoropolymer chemical delivery fittings, valves & pumps
- High purity gas delivery fittings, valves & regulators
- Instrumentation fittings, valves & regulators
- Medium pressure fittings & valves
- Process control manifolds



SEALING & SHIELDING

Key Markets

- Aerospace
- Chemical processing
- Consumer
- Energy, oil & gas
- Fluid power
- General industrial
- Information technology
- Life sciences
- Military
- Semiconductor
- Telecommunications
- Transportation

Key Products

- Dynamic seals
- Elastomeric o-rings
- EMI shielding
- Extruded & precision-cut, fabricated elastomeric seals
- Homogeneous & inserted elastomeric shapes
- High temperature metal seals
- Metal & plastic retained composite seals
- Thermal management



ENGINEERING YOUR SUCCESS.

Parker Worldwide

AE – UAE, Dubai
Tel: +971 4 8127100
parker.me@parker.com

AR – Argentina, Buenos Aires
Tel: +54 3327 44 4129

AT – Austria, Wiener Neustadt
Tel: +43 (0)2622 23501-0
parker.austria@parker.com

AT – Eastern Europe,
Wiener Neustadt
Tel: +43 (0)2622 23501 900
parker.easteurope@parker.com

AU – Australia, Castle Hill
Tel: +61 (0)2-9634 7777

AZ – Azerbaijan, Baku
Tel: +994 50 2233 458
parker.azerbaijan@parker.com

BE/LU – Belgium, Nivelles
Tel: +32 (0)67 280 900
parker.belgium@parker.com

BR – Brazil, Cachoeirinha RS
Tel: +55 51 3470 9144

BY – Belarus, Minsk
Tel: +375 17 209 9399
parker.belarus@parker.com

CA – Canada, Milton, Ontario
Tel: +1 905 693 3000

CH – Switzerland, Etoy
Tel: +41 (0) 21 821 02 30
parker.switzerland@parker.com

CL – Chile, Santiago
Tel: +56 2 623 1216

CN – China, Shanghai
Tel: +86 21 5031 2525

CZ – Czech Republic, Klecany
Tel: +420 284 083 111
parker.czechrepublic@parker.com

DE – Germany, Kaarst
Tel: +49 (0)2131 4016 0
parker.germany@parker.com

DK – Denmark, Ballerup
Tel: +45 43 56 04 00
parker.denmark@parker.com

ES – Spain, Madrid
Tel: +34 902 33 00 01
parker.spain@parker.com

FI – Finland, Vantaa
Tel: +358 (0)20 753 2500
parker.finland@parker.com

FR – France, Contamine s/Arve
Tel: +33 (0)4 50 25 80 25
parker.france@parker.com

GR – Greece, Athens
Tel: +30 210 933 6450
parker.greece@parker.com

HK – Hong Kong
Tel: +852 2428 8008

HU – Hungary, Budapest
Tel: +36 1 220 4155
parker.hungary@parker.com

IE – Ireland, Dublin
Tel: +353 (0)1 466 6370
parker.ireland@parker.com

IN – India, Mumbai
Tel: +91 22 6513 7081-85

IT – Italy, Corsico (MI)
Tel: +39 02 45 19 21
parker.italy@parker.com

JP – Japan, Tokyo
Tel: +(81) 3 6408 3901

KR – South Korea, Seoul
Tel: +82 2 559 0400

KZ – Kazakhstan, Almaty
Tel: +7 7272 505 800
parker.easteurope@parker.com

LV – Latvia, Riga
Tel: +371 6 745 2601
parker.latvia@parker.com

MX – Mexico, Apodaca
Tel: +52 81 8156 6000

MY – Malaysia, Shah Alam
Tel: +60 3 7849 0800

NL – The Netherlands,
Oldenzaal
Tel: +31 (0)541 585 000
parker.nl@parker.com

NO – Norway, Ski
Tel: +47 64 91 10 00
parker.norway@parker.com

NZ – New Zealand, Mt Wellington
Tel: +64 9 574 1744

PL – Poland, Warsaw
Tel: +48 (0)22 573 24 00
parker.poland@parker.com

PT – Portugal, Leca da Palmeira
Tel: +351 22 999 7360
parker.portugal@parker.com

RO – Romania, Bucharest
Tel: +40 21 252 1382
parker.romania@parker.com

RU – Russia, Moscow
Tel: +7 495 645-2156
parker.russia@parker.com

SE – Sweden, Spånga
Tel: +46 (0)8 59 79 50 00
parker.sweden@parker.com

SG – Singapore
Tel: +65 6887 6300

SK – Slovakia, Banská Bystrica
Tel: +421 484 162 252
parker.slovakia@parker.com

SL – Slovenia, Novo Mesto
Tel: +386 7 337 6650
parker.slovenia@parker.com

TH – Thailand, Bangkok
Tel: +662 717 8140

TR – Turkey, Istanbul
Tel: +90 216 4997081
parker.turkey@parker.com

TW – Taiwan, Taipei
Tel: +886 2 2298 8987

UA – Ukraine, Kiev
Tel: +380 44 494 2731
parker.ukraine@parker.com

UK – United Kingdom,
Warwick
Tel: +44 (0)1926 317 878
parker.uk@parker.com

US – USA, Cleveland
Tel: +1 216 896 3000

VE – Venezuela, Caracas
Tel: +58 212 238 5422

ZA – South Africa,
Kempton Park
Tel: +27 (0)11 961 0700
parker.southafrica@parker.com

European Product Information Centre
Free phone: 00 800 27 27 5374
(from AT, BE, CH, CZ, DE, DK, ES, FI, FR, IE,
IT, NL, NO, PL, PT, RU, SE, UK, ZA)

